



# SCALE-MAIL

## Contents

### Bulletin Board

### MOTAT Military theme Day

### Eduard Messerschmitt Bf 109G-14

### Eduard Bf 110 Instrument Panel

### AC MODELS 1:35th NZ STAGHOUND SET, ITALY.

## NEXT MEETING

Tuesday 17th April 2018

Leys Institute (upstairs)

20 Saint Marys Road

Ponsonby

## COMMITTEE

|                           |                |
|---------------------------|----------------|
| Chairman - John Swarbrick | Craig Sargent  |
| Secretary - Brett Peacock | Lance Whitford |
| Treasurer - Mark Robson   | Keith Bunyan   |
|                           | Mike Maran     |

EDITOR: Lance Whitford

e: lancewhitford@hotmail.com

WEBMASTER: Robert Willis

e: jaxbw@orcon.net.nz

EMAIL: ipmsauckland@gmail.com

WEB: ipmsauckland.hobbyvista.com

YAHOO:  
groups.yahoo.com/group/ipmsauckland

FACEBOOK:  
Link from the IPMS Auckland Website

## From the Editor

It's AGM time again this month! Time to ask yourself not what your club can do for you but what you can do for your club as the saying goes. The club does not run all by itself and we always welcome fresh faces into the committee. As club committee's go ours is not one with particularly onerous duties and the odd committee meeting is usually quite sociable.

On another note, it appears that Modelex 2018 will NOT be happening. The word is that there is insufficient interest from prospective participants to make the event viable. The show has seen declining numbers of stands over the past few years and the show was a fair way from it's glory days but it does mark the passing of a significant event on the Auckland Hobby scene. IPMS has had along standing association with the event and we have gained many new members as a result.

## MOTAT Military Theme day Sunday -18 March

The MOTAT Military theme Day that some of us participated in was a very enjoyable event. Nearly 3000 people attended the one-day event which featured military displays, rides on military vehicles and an aerobatic display courtesy of the RNZAF. We were located in the massive aviation hall and I must say as a first-time visitor to this venue I was really impressed by the quantity and quality of the aircraft in the permanent display. No more corroding bodies out in the weather. We are hoping to use this space when we next host the nationals.

IPMS put on a good display of models that got a good deal of positive (and a little negative) attention. It's on thing keeping kids from touching but here were a few adults who should have known better. Those of us that attended also had the opportunity to get a little 'bench-time' in. I have included a few photos of the day later in this newsletter. I'm keen to do it again.

# BULLETIN BOARD

**NEW MEMBERS AND SUBS \*\*\*\*\* 2018/19 NOW DUE \*\*\*\*\***

**Subs for 2018/19 now DUE - see below for club account details or see the club secretary  
at the next club meeting.**

| <b>Membership Type</b> | <b>Description</b>                                | <b>Cost</b> |
|------------------------|---|-------------|
| Full                   | Living in the Auckland Metropolitan Area          | NZ\$45      |
| Out Of Town            | Living 75km or more from central Auckland         | NZ\$30      |
| Junior                 | Same rights as full membership for those under 16 | NZ\$25      |

**IPMS BANK ACCOUNT NUMBER**

**03 0162 0012960 00**

***Please add your name and details  
so we know who has paid!***

## EVENTS

### **CLUB NIGHT EVENTS**

**IPMS Auckland Meet on the 3rd Tuesday of every Month at the Leys Institute (upstairs), 20 Saint Marys Road, Ponsonby**

- **17 April** AGM and normal meeting activities
- 
- 

### **MODELLING EVENTS**

Nothing new to report the month!

## CLUB SUPPORT

The following retailers have kindly agreed to offer IPMS Auckland club members a discount on their purchases upon presentation of their current IPMS Auckland Membership card.

The discount only applies on selected product lines and remains at the discretion of the retailer.



### ModelAir

349 Dominion Road  
Mount Eden  
Auckland  
p: 09 520 1236



### Stoker Models

Cnr Market Rd & Gt South Rd  
Auckland  
p: 09 520 1737  
10% on kits and modelling supplies



### TOYWORLD

Toyworld Henderson  
56 Railside Rd, Henderson  
Toyworld Westgate  
1 Fernhill Dve, Westgate

15% Off the normal retail price on:

- All models and modeling accessories
- All Hornby
- All Siku
- All Schleich & Collecta figures and accessories
- All Meccano
- Lego (Excludes Lego Mindstorm's they will be 10% if available as most have already been pre-ordered)

(Note: not in conjunction with any other promotion)



### Merv Smith Hobbies

27 Davis Crescent  
Newmarket  
Auckland

10% off most items on presentation of IPMS Auckland Membership Card.

---

### Avetek Limited

Gwyn and Christina Avenell  
28 Lauren Grove, RD 2, Pakura,  
Auckland 2582, New Zealand.

p: +64 (09) 298 4819,  
m: +64 (0)27 343 2290  
e: aveteknz@gmail.com

www.avetek.co.nz  
New Zealand Master Agents for:

Auszac ECO Balsa • Bob Smith Industries - Cyanoacrylates and Epoxies • Airsail International Kitsets

---

# Images from the MOTAT Military theme Day















## Bf 109G-14

**ProfiPACK**  
edition



1/48 scale

**eduard**

**In Box Kit Review.** Kit purchased at The Model Room, Papakura, Retails at \$80.00 (NZ)

### Historical Note:

By late 1942 the ReichsLuftsMinisterium (German Air Ministry or RLM) decided that the now aging Bf109 needed to be armed with heavier weapons to keep pace with the tempo of the air war as it was developing. The early G Models, (G-1 thru G-4) were still armed with the same guns as the standard F Model, to wit, 2x7.9mm Machine guns and 1 engine mounted 20mm cannon. As far back as the introduction of the F model some pilots (like Adolf Galland) bemoaned the decrease in firepower compared to the E model – which had 2 additional 20mm cannon in the wings although many E models omitted the (at that time) troublesome engine mounted weapon. To address this the new Models (G-5 and G-6) were to feature 2x 12.7mm (51cal) heavy machineguns mounted in place of the 7.9mm machine guns and provision for Either a 20mm OR a 30mm engine mounted cannon.

The new heavier Mgs however presented a new problem – their feed mechanism was considerably larger than the 7.9mm feed and necessitated that a housing be added to the upper nose to clear it, giving the nose cowling 2 distinctive bulges over the breeches of these machine guns (and giving the G-5 & 6 models a whole new nickname – "Beule" or "Bulge").

on the minus side of the ledger, the new model was a little slower (drag) and heavier than the G-4 it began to replace. But it remained the most-produced single variant of the 109 until the end of the war. (many G-14 and G-10s were re-engineered from G-6 Airframes and components....)

To the BatKit, Robin!:

This is another Profipack boxing of the New & re-tooled 109G kit by Eduard and features the late war 109G-14 variant. The G-15 was another attempt to rationalise and standardise 109 production, which had become fragmented and almost incompatible with itself between Erla, WNF and Messerschmitt made machines. Initially the G-15 was produced alongside the G-6 and later alongside the G-120, So that didn't work out too well!

The kit has 5 markings options for the modeller to choose from which are:

**A: White 1** – Flown by Staffelkapitein Erich Hartmann of 4/Jg52 in October of 1944, Csor, Hungary. Painted in standard RLM 74/75 over 76 greys, with the famous Black Tulip motif around the engine cowling. Hartmann's scoring slowed significantly in this machine as the Russians would vacate the area once he was spotted in the air. In November he had it removed and his scoring went back to its previous level.

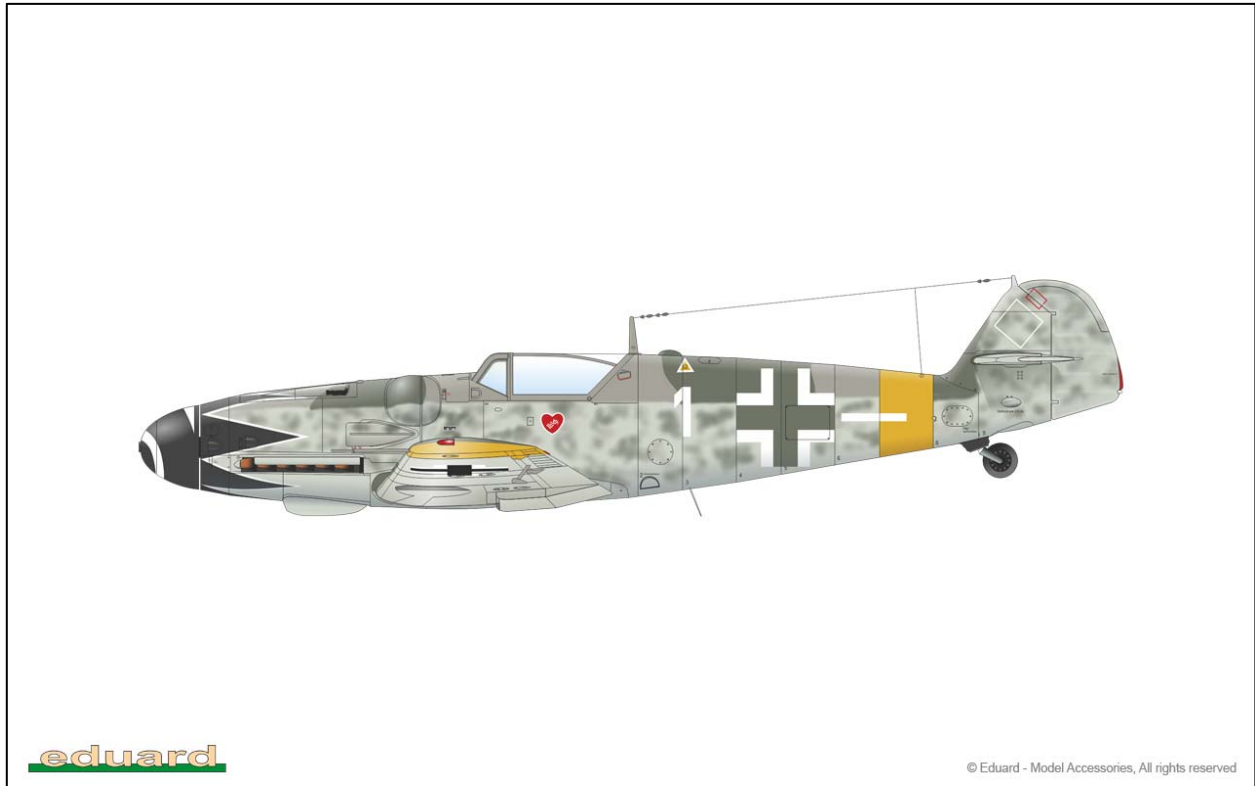

**B: Blue 3** – Leutnant Horst Schlick 4/Jg77, Schoenwalde, Germany, November 1944 Again, standard Greys RLM 74/75 over 76 with white spinner spiral and yellow lower cowling. Carries a 300 litre Drop Tank and rack.

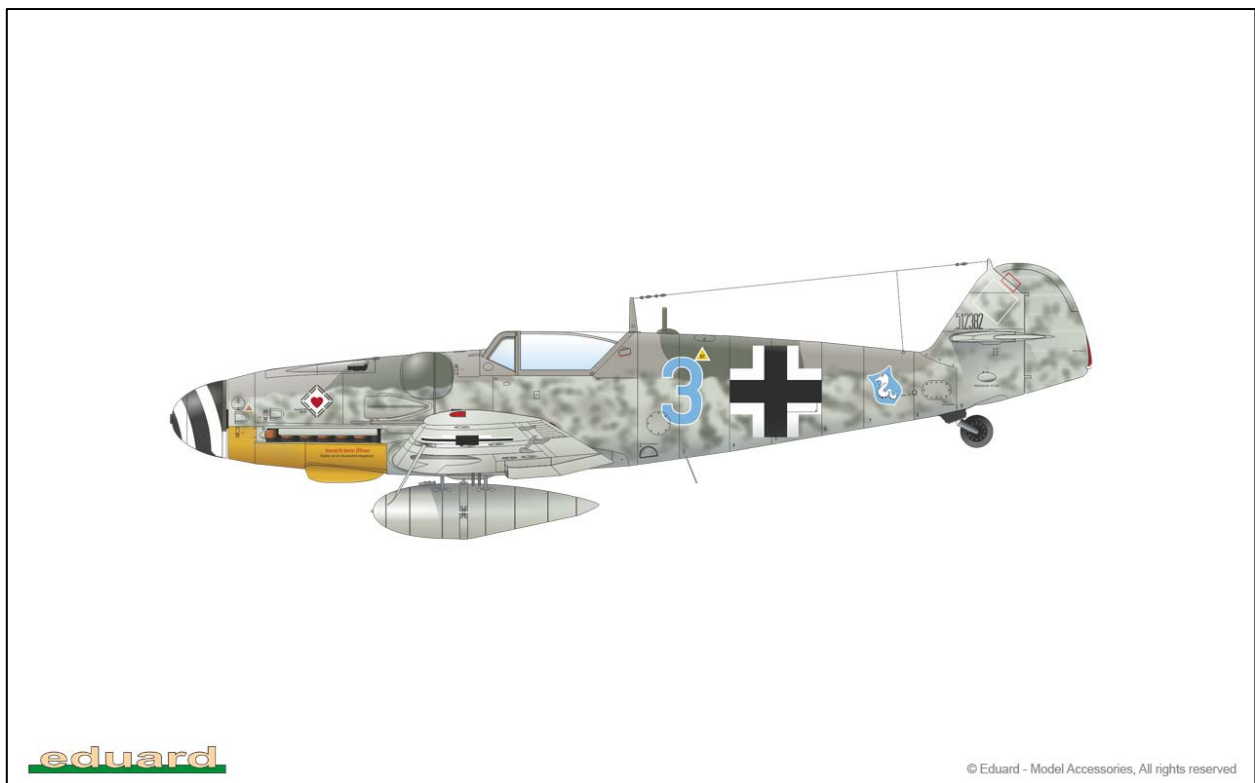

**C: Yellow 1** – Maggiore Mario Beligambi, 5 Sqdrigla, 2 Gruppo, ANR, Osoppo Italy, March 1945.. Standard 74/75 over 76 with some German unit markings over painted with Italian Olive green. The rudder is of the very late war type with solid Lichtgrun 82 base and Braunviolet 81 patches. The lower cowling is again yellow and the spinner has a white spiral. It is possible, given the late dating that the uppers were in 83/75, not 74/75. The Flag emblems of the ANR were non-standard, as they had the thin yellow zigzag outline on all 4 sides, and not with a thin straight outline on the leading edge to represent a flagpole.

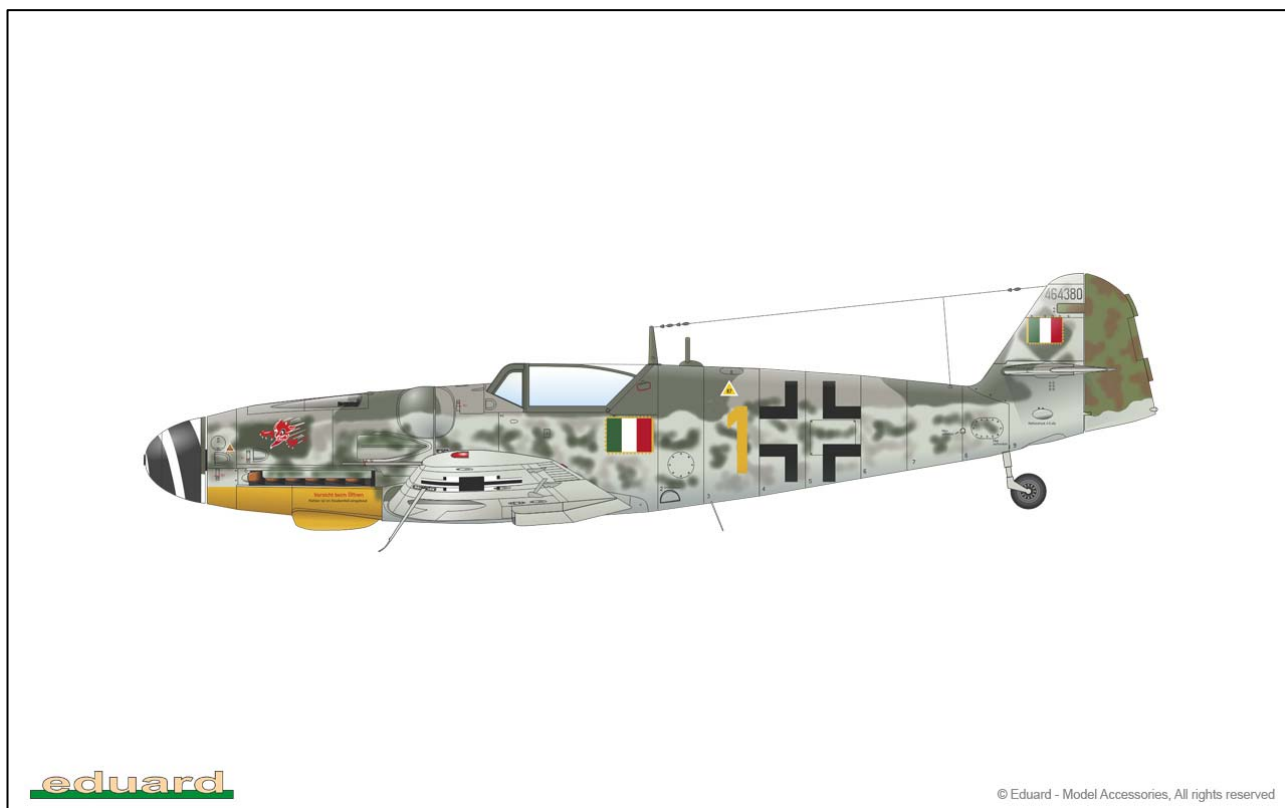

**D: Black 8** – Oberleutnant Rolf Schlegel, CO of 10/Jg4, Juterborg-Damm, Germany, March 1945. RLM76 over RLM 76 with Black/White/Black RVD bands on the rear fuselage. This machine shows evidence of repainting from an earlier scheme as the number has been applied over a large patch of RLM74. It carries a 300 litre drop tank and rack.

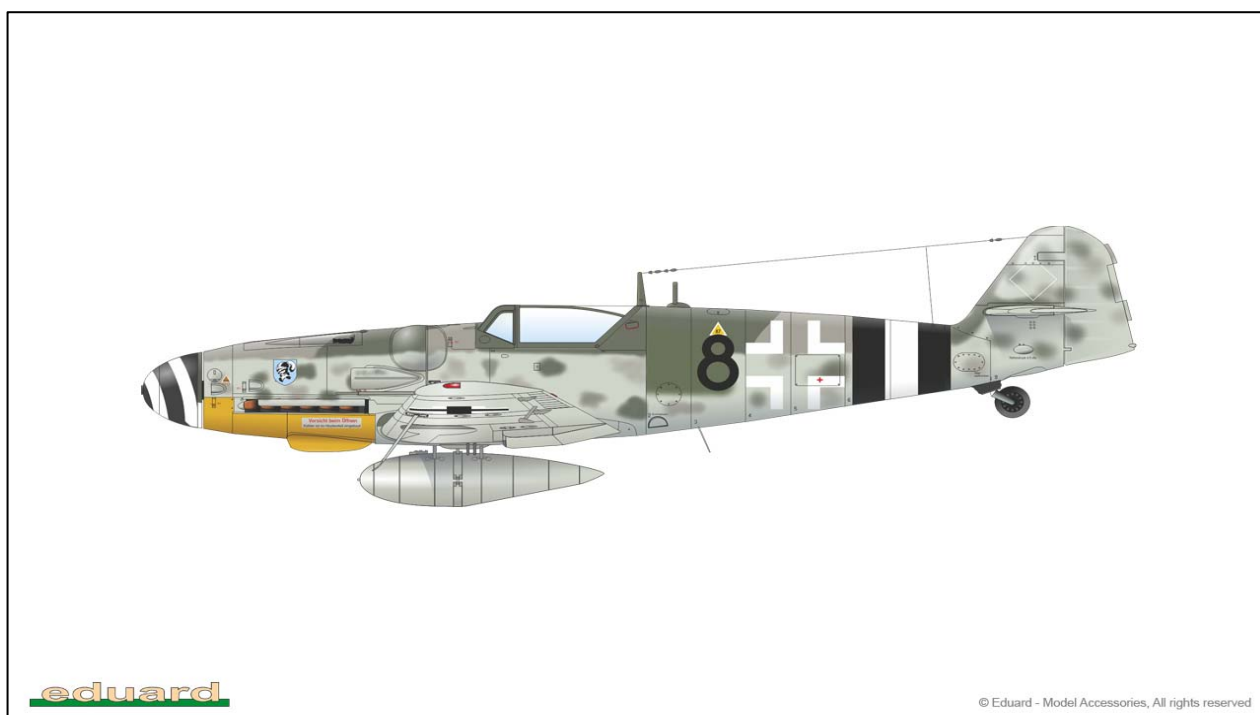

**E: Yellow 25** - Pilot uncertain, EJg 2, Pilsen, Czechoslovakia May 1945. Again standard RLM 74./75/76 scheme with yellow lower cowling. The rudder is shown as yellow, but the photo source is acknowledge by Eduard to be a different airframe of the same unit, so may not be accurate. Thin Green RVD band behind the Fuselage cross. EJg 2 was a bomber pilot conversion unit for KG 55 pilots, hence the use of a KG55 emblem as a unit insignia. It may or may not have had a yellow background for this emblem. The white spinner spiral is also very thin, compare to the others



Judging from the reviews and build logs of the earlier G-6 kit this will be like their Spitfire kits to build – excellent surface details, well engineered, well fitting and easy to finish.



The kit itself has extremely well done and very fine recessed (with some subtly raised, panel and rivet detail – so fine, in fact, that you will need to apply a VERY well-thinned coat of paint to avoid hiding it. Brush painting this kit will not work. The Plastic is in a very Tamiya-like medium to dark grey and the kit has four sprues trees of this and 1 clear tree. Colour Photo Etch and die-cut masks (by Eduard, of course!) are included. (NOTE: There is an incomplete section in the Instructions for those masks, but it should not be impossible to work out the right mask panels to choose.)

There are 176 parts for the kit and that does not include over 70 parts marked as surplus. (A Bonanza for the Spares box!)

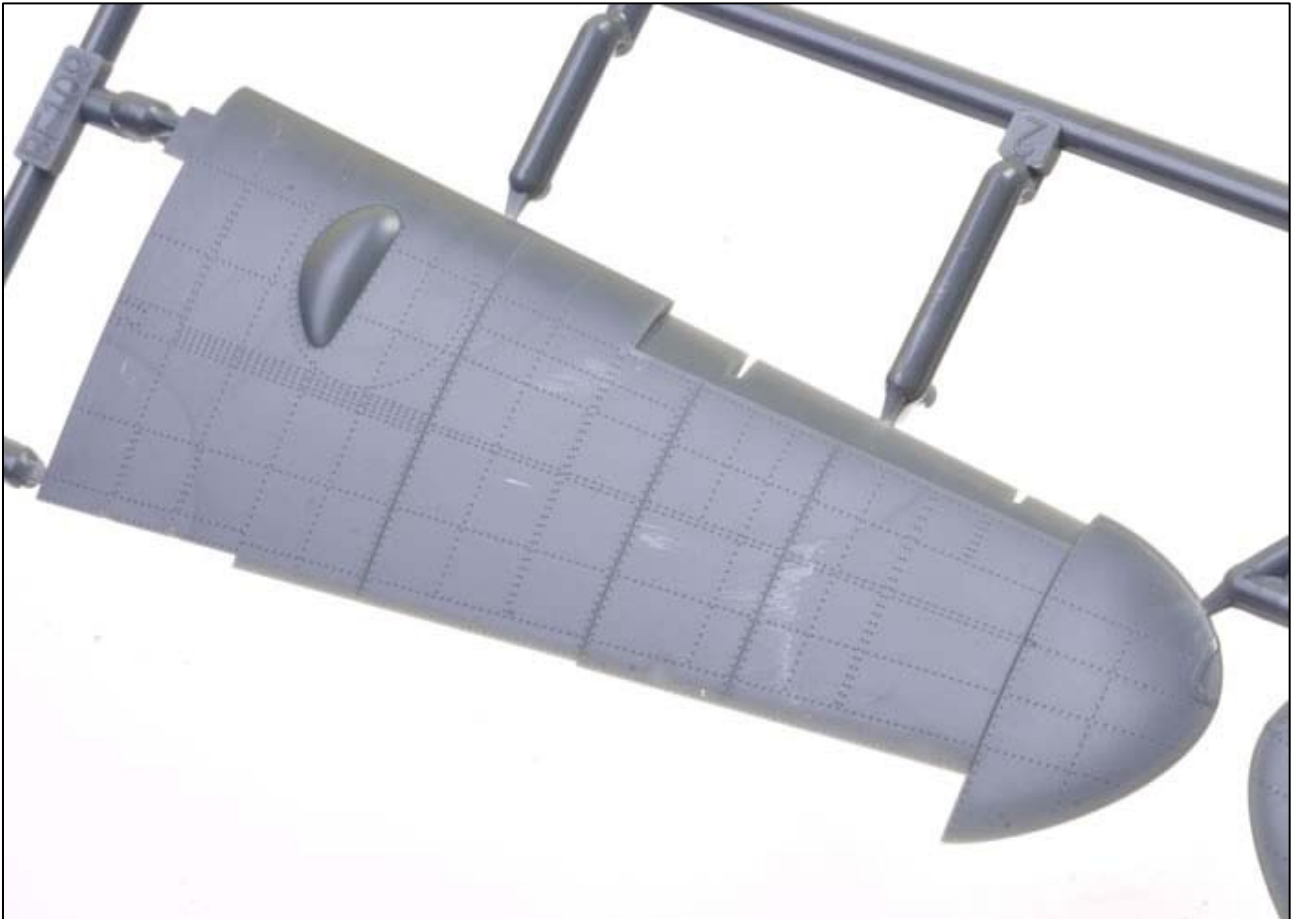

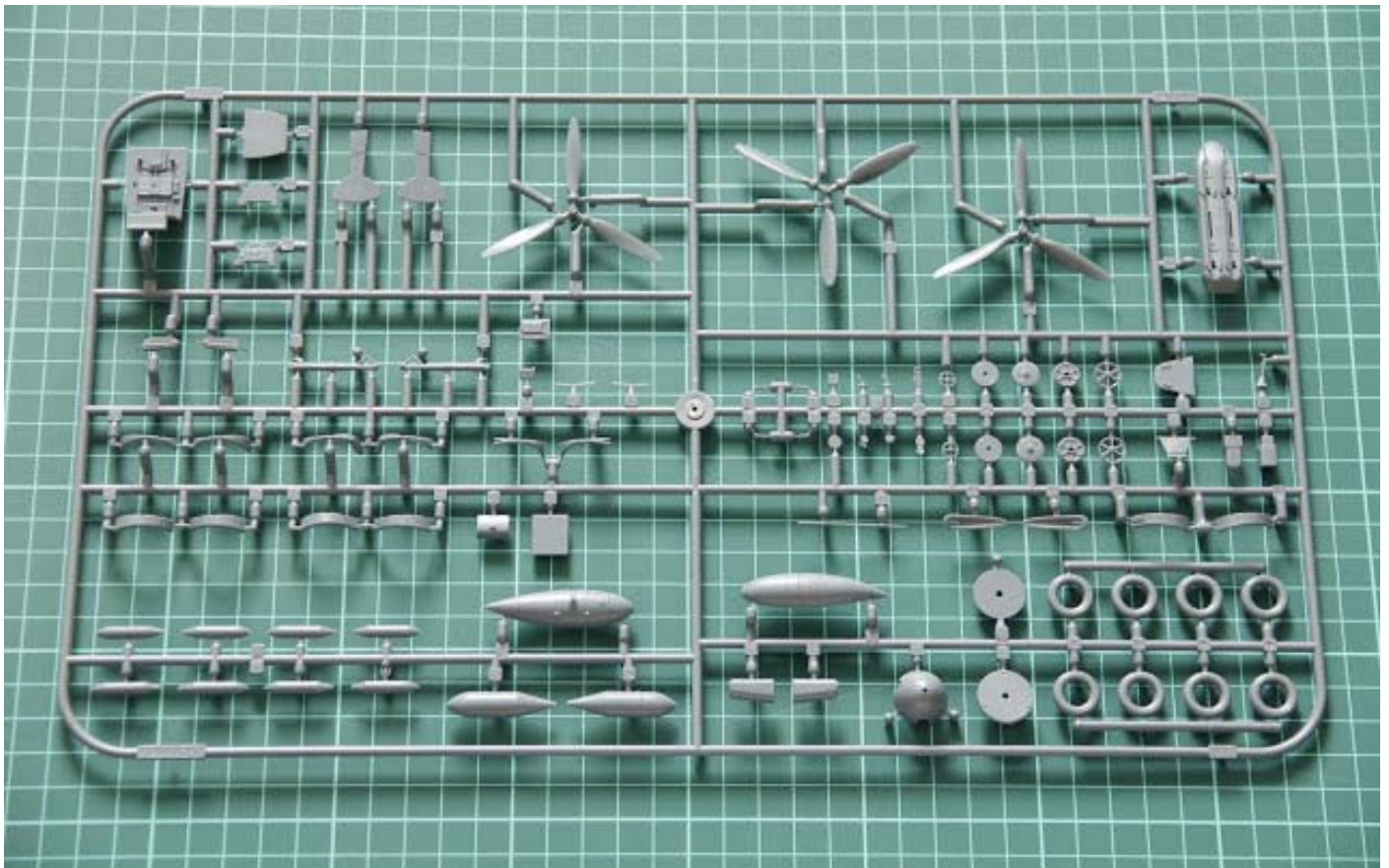

On a note regarding those spares – There is a smaller, slimmer supercharger intake on those parts marked surplus and I note with interest that the wings and fuselage halves all come on smaller separate sprue trees, meaning that the F model will follow in due course, as will (probably) both the early G-1 to G-4 models And the Later AS engined models. No fewer than 2 tall fins (wooden and metal) and 3 tall rudders are also on the surplus list. Surplus also are a second drop tank, Bombs (without fins – I'm guessing that the fins will be supplied as Photo etch parts.) There are also 3 propellers – only 1 of which is used, another very closely resembles the prop for an F model.

Note in the image on the left that the exhausts are hollowed out.... No resin parts necessary! No fewer than 4 sets of tyres for the wheels are also included and 2 styles of wheel hubs. Oddly missing from the weapons array provided is a pair of Wfgr 21 Grenate tube launchers and the Rockets.



Even the decal sheet has spares... 2 decal sheets are included. 1 sheet, the larger, has all the individual markings, insignia and numbers. The other sheet has Stencil markings... & as far as I can tell, it actually has 2 complete sets of stencil markings! Both sheets are in perfect register, and the tiny stencils are legible even at 2x or 3x magnification.

The plastic in the kit is the same sprues as are found in the G-5 and G-6 kits, with some small differences in the PE fret and the Masking sheet included in the Profipack edition. This is to cater for the slight changes in the cockpit between the earlier variants and this one. I do like the marking options – The one from Pilsen deserves a Pilsener toast!

### **Conclusions and Recommendation:**

From my earlier G-5 review a few months back:

“Yes, at \$NZ 80.00, this is quite expensive, even for these days, but on the other hand, it is hands down, the best 1/48 Bf 109G kit on the market at the moment. Is it perfect? No kit is perfect. But it gets very close to it, indeed. But it will build into a very good replica without resorting to resin and/or correction sets, and the colour PE parts will mean you will want to open up the cockpit to show off the details therein.”

Well, the only change would be to note that Tamiya have now claimed that title (Best 109G-6) and their kit is cheaper than this one (I now have 2 of the Tamiya and 4 of the Eduard G's, so I'm not biased at all.), but the caveat is that Tamiya is best ONLY if you want to build a G-6 Messerschmitt made early to mid-production Bf 109G-6. For a G-5 or G-14 you can still buy Eduard with confidence. (heck you can also get Eduard for a G-6 from Erla or WNF too!)

Highly recommended, even if you can only afford to get 1, it is worth getting. - That conclusion, I stand by



# Eduard Bf 110 Instrument Panel

by Mark Davies



## Summary:

Catalogue Number:

14001

Scale:

1:4

Contents & Media

1 x dark grey panel and 39 x black styrene bezel parts, 26 clear styrene instrument face and bulb parts, 2 x pre-coloured PE fret of instrument placards & needles and 1 x self-adhesive vinyl sheet of instrument faces.

Price:

Available on-line from:

[Eduard for US\\$29.95](#)

[Hannants for £14.16](#)

[Squadron for US\\$29.96](#)

[Modelimex for €14.58](#)

Review Type:

First Look

Advantages:

Great idea for an interesting display item, high quality production of components.

Disadvantages:

Nothing significant.

Conclusions:

A great project for a change of pace from your regular modelling projects. This is a top quality package that should result in a very attractive display piece.

## BACKGROUND

Despite struggling in the battle of Britain to live up to the Luftwaffe's expectations as long-legged heavily armed destroyer when confronted with modern single-engined fighters, the BF 110 never the less provided long and useful service throughout WW2. It proved a useful work-horse and came closest to fulfilling its destroyer function when confronting unescorted day USAAF day bombers, as well as combating the RAF in the night-fighter role.

I have always liked the Bf 110, especially the early versions, regarding it as one of the more elegant and aesthetically pleasing of German designs. So it was some interest that I examined the contents of Eduard's 1:4 scale instrument panel for a Bf 110C.

## THE KIT

This is a reissue as the instrument panel was previously a bonus extra in Eduard's Bf 110 C/D/E Royal Class twin kit boxing of the Bf 110. The kit comes in a good quality top-opening box with an image of the completed instrument panel. Inside the various styrene parts are sealed in cellophane, and the pre-coloured PE fret and self-adhesive instruments come in zip-lock plastic bags. Clear and self-evident instructions include a parts map and diagrammatic assembly steps. Other instructional requirements are provided using symbols tied to a key in English, French, German and Czech.

The quality of the parts is excellent across all media. The panel itself, instrument bezels, screw heads and switch bodies are moulded in black styrene; whilst clear styrene is provided for the instrument glass. A self adhesive vinyl sheet has very clearly printed instrument faces, and the coloured PE fret caters for various placards and some instrument needles etc.



Assembly looks to be very straightforward, but obviously care following the instructions will be needed to make sure all the dials and placards are in the right places (the vinyl instrument faces have a tab to align with a notch within the bezel to help with this). There are also some small and fiddly parts despite the kit's very large scale, so again care and patience will pay off. In fact it's really a case care rather than high skill levels being all that's needed to achieve a very high quality of finished product here .

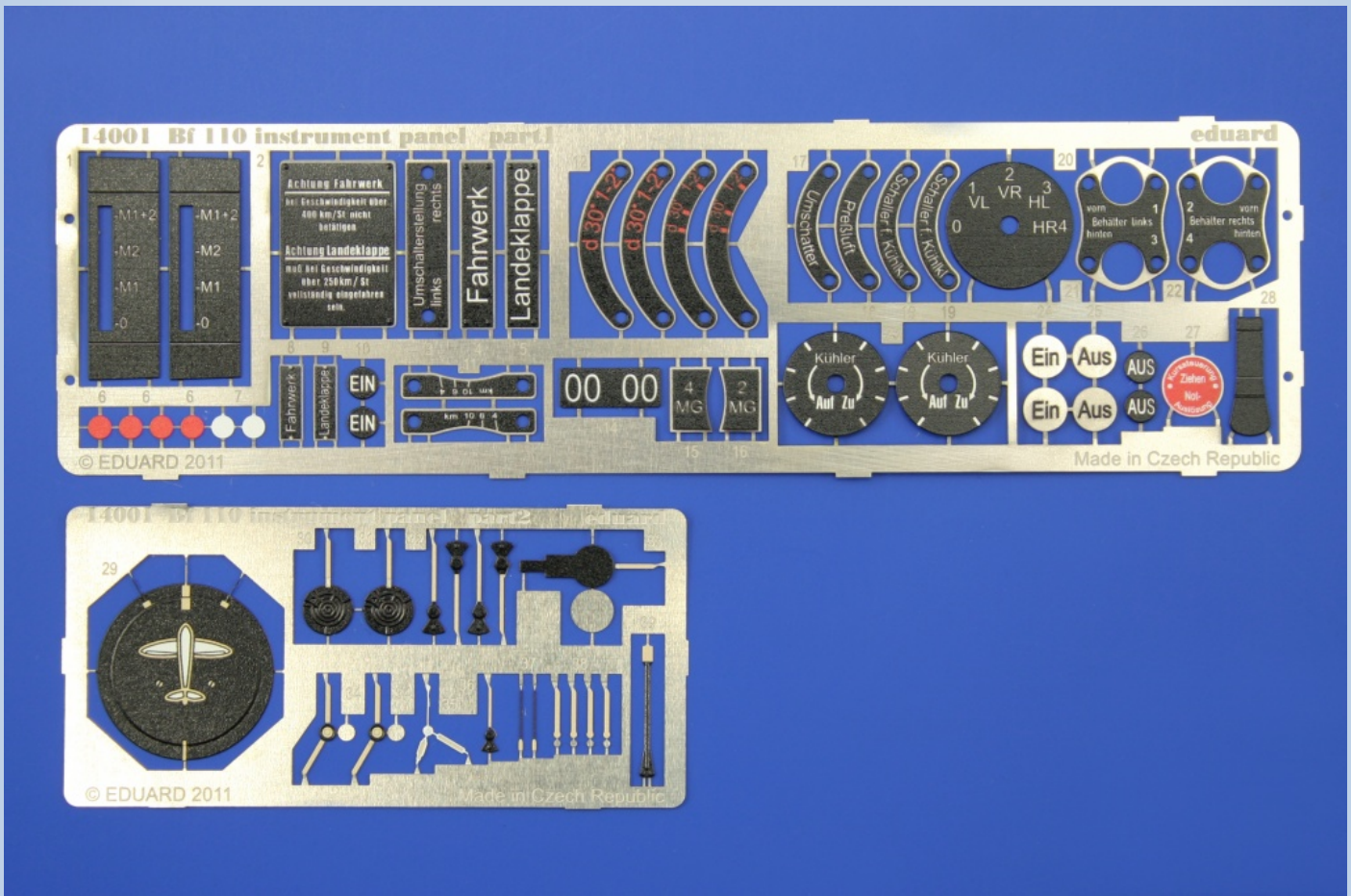

## CONCLUSION

This is an excellent quality package produced the high standards we have come to expect of Eduard. The concept is an interesting one, and I should think that it has the potential to appeal to a range of modellers. The kit will demand care more than skill to achieve a high quality finish. It could be just the tonic for modeller's block or a relaxation after a demanding project. The finished result will certainly look good as in any model room, den or display location.

I can't help but think that this type of kit would sell best if part of a series or collection. I'm sure, despite my fondness for the Bf 110, that there are other more popular subjects that Eduard could issue instrument panel kits of to the same scale.

It should be no surprise that I thoroughly recommend this kit.

Thanks to [Eduard](#) for these review sample and the images used with this review.

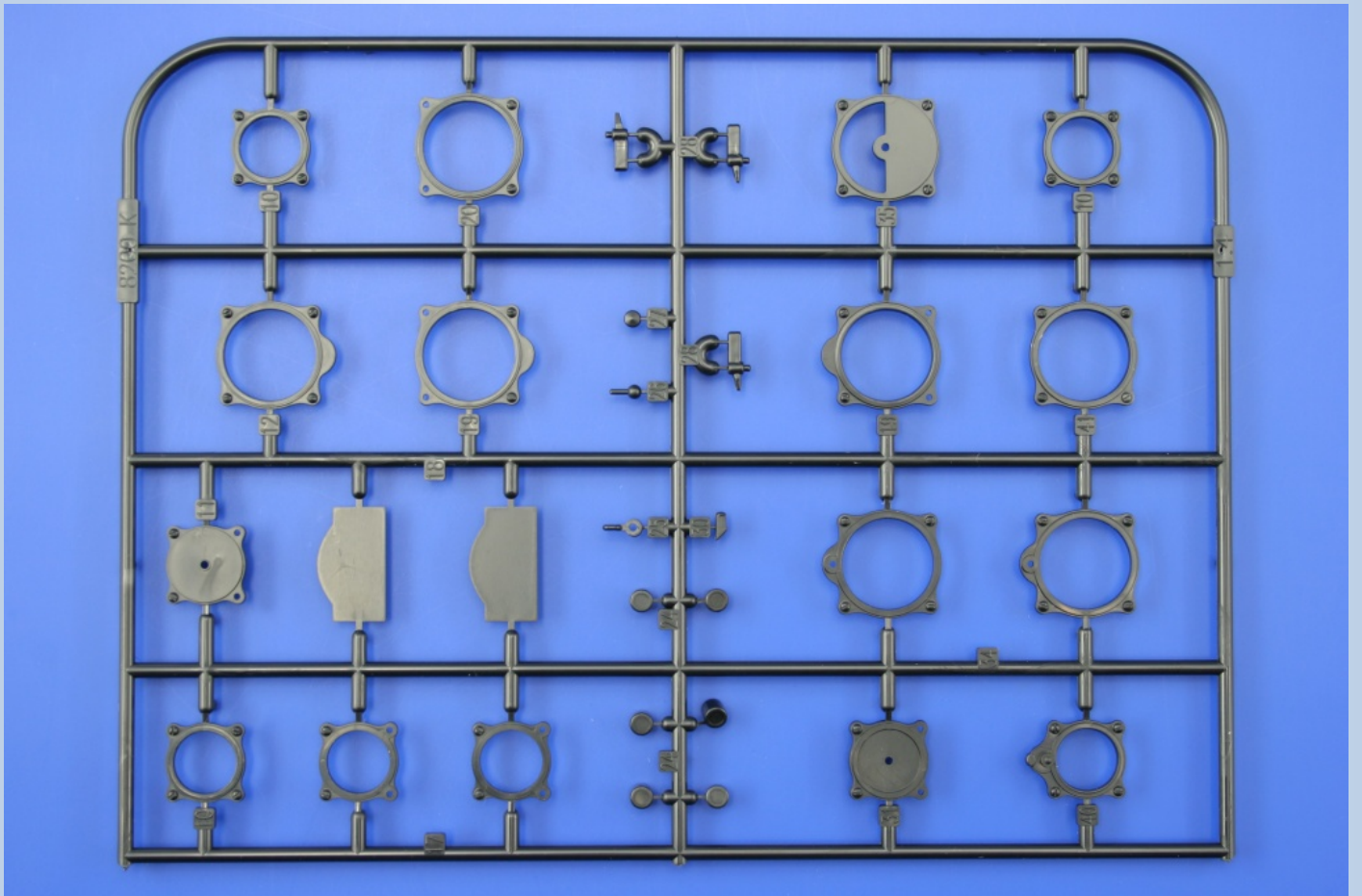
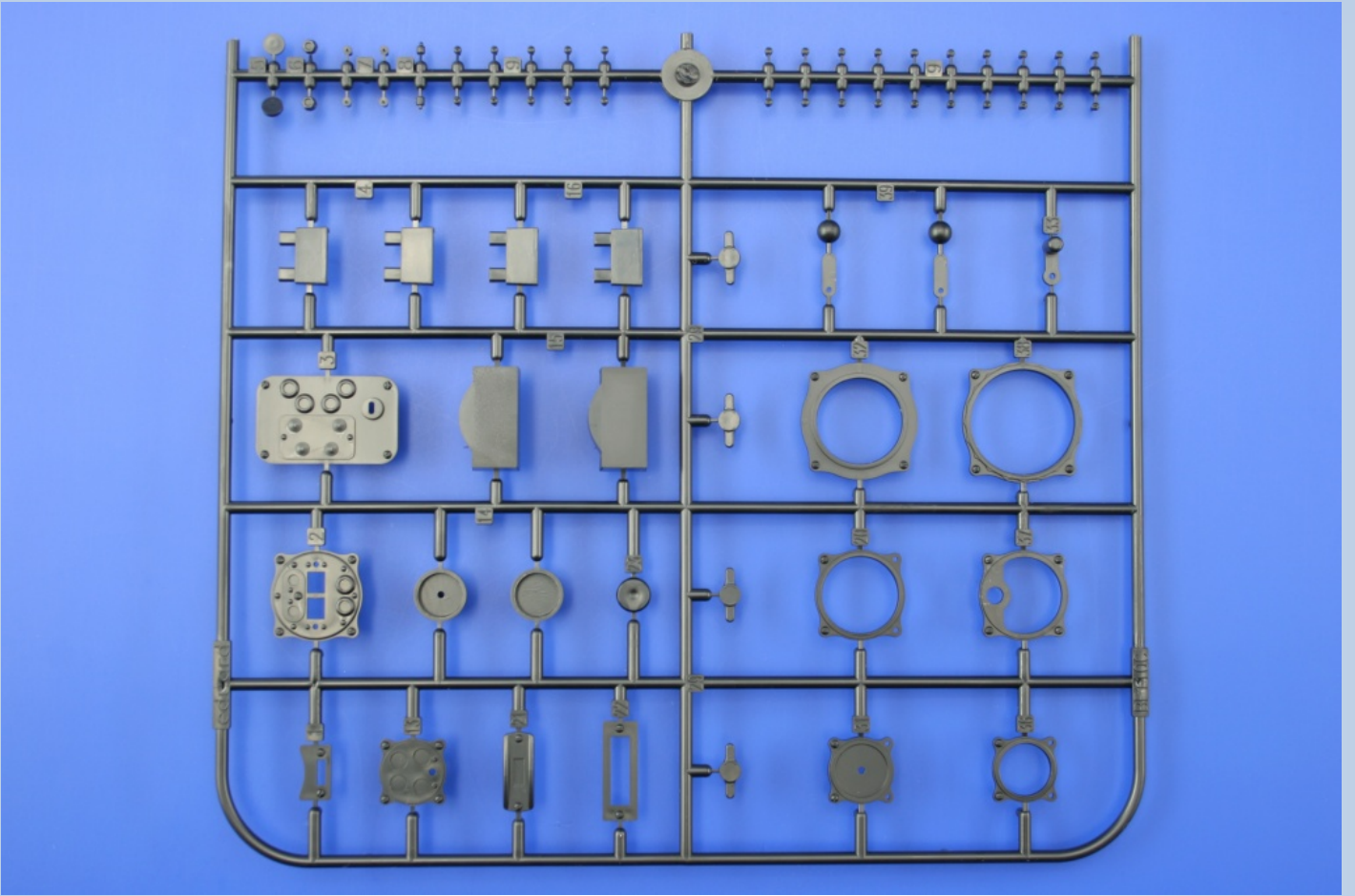

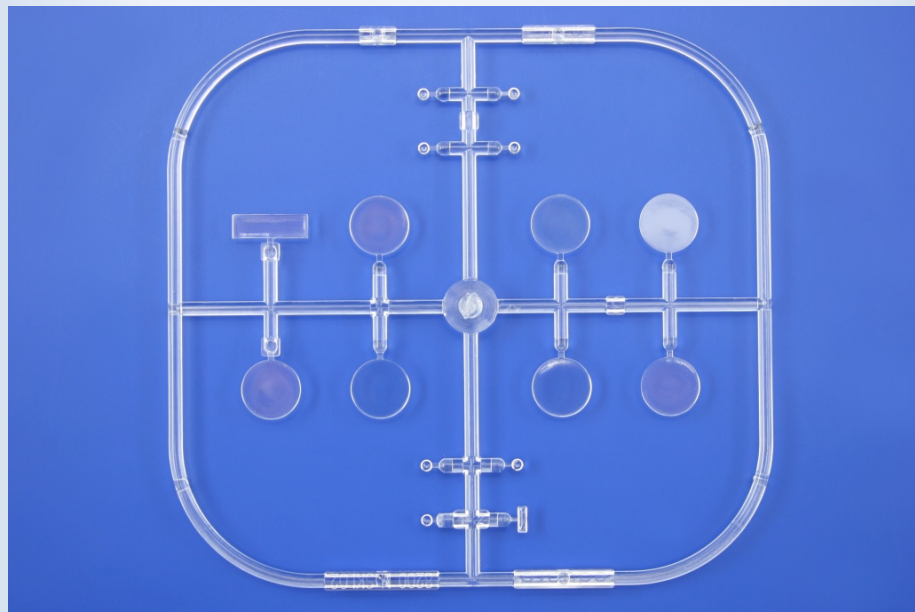
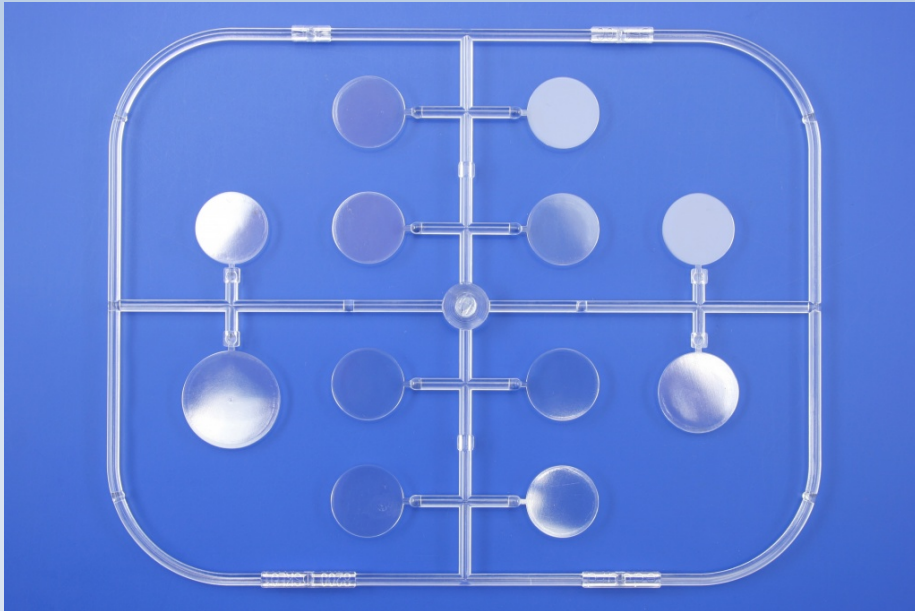

# AC MODELS 1:35th NZ STAGHOUND SET, ITALY.

## KIT AC35008

A look in the box by Pete M.



This next set from AC Models is mainly a stowage set for a Kiwi Staghound operated by the 2nd NZ Divisional Cavalry Regiment in Italy, but does include two figures.





Moulded in a light grey resin, this set includes most of the stowage commonly seen in photos of this unit's Staghounds taken in Italy, and matches the illustration sketches as held in the Alexander Turnbull Library as below

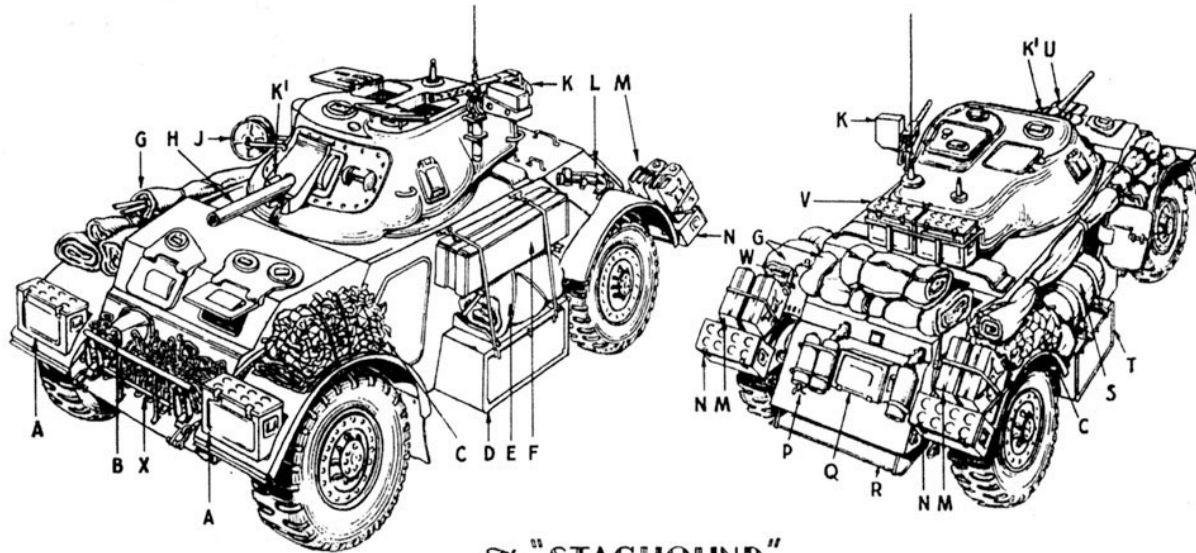

*The "STAGHOUND"*  
Armoured Car —

Dunnage Equipment & Sundry Improvements.

- |   |  |
|---|--|
| <p>A 25 Pdr boxes</p> <p>B .30 Browning machine gun mounting (not used)<br/>The gun is mounted on top of, or on the side of the turret (as shown in K)</p> <p>C Camouflage net</p> <p>D Tool box</p> <p>E Tarpaulins, bivvies etc</p> <p>F Mine detector</p> <p>G Crew's bivvies, bed rolls, poles etc</p> <p>H 3" Howitzer and mounting. This gun replaces the 37mm gun on the Troop Officers car</p> <p>J Remote control phone cable</p> <p>K-K1 .30 Cal machine guns, Browning</p> <p>L Shovel, Axe etc</p> <p>M Two 5 Gal. cans, water</p> <p>N 25 Pdr boxes, permanently attached to rear mudguards. Supporting brackets form recess for two 5 Gal cans (asat M)</p> | <p>P Crew's hot water supply. The water container is made from a shell case, fitted with tap, screw cap filler and strapped to exhaust muffler.</p> <p>Q 4.5 Amn Box. Permanently attached to back plate</p> <p>R Dust tray</p> <p>S Jettison tank</p> <p>T Tucker box</p> <p>U 37mm Gun</p> <p>V Two 25 Pdr boxes and tray. Tray is welded to rear of turret</p> <p>W Benghazi burner</p> <p>X Tyre chains and towing cable. Retaining grill of tubular steel, strap iron, or other suitable material welded in place.</p> <p>Note Any of the above improvements, apart from armaments are not necessarily standard but are fitted to crew's individual requirements.</p> |
|---|--|

Staghound Dunnage stowage diagram by J Figgins.  
(Alexander Turnbull Library, DA10472)



Most of the castings are very well done, but my example has a few pinholes here and there, a lot of flash and a few surface imperfections that will require cleaning up. Several items will require cutting off the pour stubs. The representations of the 25lb boxes are not very well done, and even the Bronco or Resicast items are far superior.



I must admit I was initially a bit disappointed with this set, as seeing the original small photos of the set, I thought Andy had provided the modified gun rotor with counterweights and the gun tube for the 3' howitzer conversion for a Mk.II Staghound. What he has provided is a gun rotor mounting plate and 37mm gun tube with covers in place. Neither look that convincing to me!



The balance of the stowage items are very well done, and his front glacis plate stowage with a chain is very convincing, even down to a missing headlamp assembly. The rear plate stowage also includes the hot water cylinder fitted to the left hand muffler body seen on most of the Kiwi Stags. I've not seen a photo of the mufflers with wrapping such as he has provided

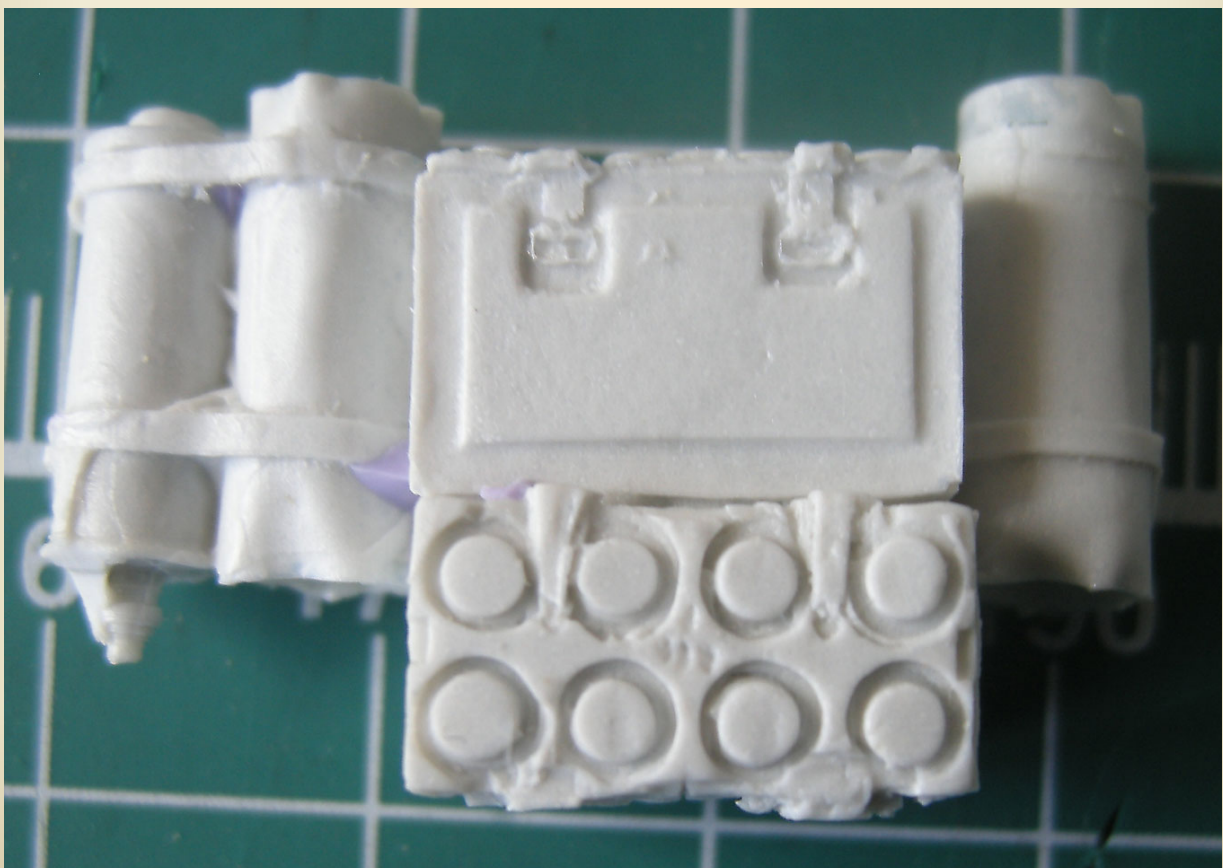



The two figures provided are not quite as good as those I previewed in my first article on AC Models Sherman crew kit, other than the heads which are surprisingly far better. These two full figures are designed to fit into the turret hatches, but could be adjusted to fit anywhere. Both are wearing the khaki drill shirts and trousers, with the Tank Corps beret with goggles and headphones. There is a lot of flash evident on my two examples, and quite a few pinholes that will need to be dealt to!

This is the only set of the three that has any instructions, and then just a small printed strip with two photos! One will have to peruse the various Jeff Plowman books to mix and match the stowage depending on which vehicle is being modelled.



# GALLERY

CLUB NIGHT MODELS

Check out our Website gallery for photos taken of models at our monthly meetings

<http://ipmsauckland.hobbyvista.com>



And as usual - check out the IPMS Auckland website as we're trying to keep the content a bit more dynamic. We won't be regurgitating content found on other websites but will provide links to sites we think are of interest to members.

