



SCIENCE MAIL

Contents

Bulletin Board

New Zealand Motorcycle Show 2018

Book Review— The Battleship Bismark

Airfix 1/48 F-51D Mustang (Post War)

DIY Magnetic Painting Handle

NEXT MEETING

Tuesday 18th December 2018

Leys Institute (upstairs)

20 Saint Marys Road

Ponsonby

COMMITTEE

Chairman - John Swarbrick Dave Stewart

Secretary - Brett Peacock Lance Whitford

Treasurer - TBC

EDITOR: Lance Whitford

e: lancewhitford@hotmail.com

WEBMASTER: Robert Willis

e: jaxbw@orcon.net.nz

EMAIL: ipmsauckland@gmail.com

WEB: ipmsauckland.hobbyvista.com

YAHOO:
groups.yahoo.com/group/ipmsauckland

FACEBOOK:
Link from the IPMS Auckland Website

From the Editor

It's been a busy year for us with a couple of open day events with MOTAT, The New Zealand Motorcycle Show and also the nationals being held relatively close to Auckland this year.

Congratulations to those that won a prize last month. Don't forget the presentation is this month. We will be having a quick meeting at the Leys Institute before abandoning to our traditional Christmas drinks at the Cavalier Tavern. Look forward to seeing you there.

For those that asked about airbrushes last month I have a couple that I will bring along to the meeting along with some spare parts and other bits an pieces



BULLETIN BOARD

NEW MEMBERS AND SUBS *** 2018/19 NOW DUE *******

Subs for 2018/19 now DUE -see below for club account details or see the club secretary
at the next club meeting.

Membership Type	Description	Cost
Full	Living in the Auckland Metropolitan Area	NZ\$45
Out Of Town	Living 75km or more from central Auckland	NZ\$30
Junior	Same rights as full membership for those under 16	NZ\$25

IPMS BANK ACCOUNT NUMBER

03 0162 0012960 00

*Please add your name and details
so we know who has paid!*

EVENTS

CLUB NIGHT EVENTS

**IPMS Auckland Meet on the 3rd
Tuesday of every Month at the
Leys Institute (upstairs), 20
Saint Marys Road, Ponsonby**

18th December Prizes will be awarded for
November's winners fol-
lowed by our traditional end
of year drinks at the Cav.

15th January Workshop -Exhausts and
staining

19th February Workshop— Using and cre-
ating masks to paint mark-
ings

19th March Workshop— Basics of seam
filling and sanding

MODELLING EVENTS

Nothing on the events front this month

BULLETIN BOARD

CLUB SUPPORT

The following retailers have kindly agreed to offer IPMS Auckland club members a discount on their purchases upon presentation of their current IPMS Auckland Membership card.

The discount only applies on selected product lines and remains at the discretion of the retailer.



ModelAir

349 Dominion Road
Mount Eden
Auckland
p: 09 520 1236



Stoker Models

Cnr Market Rd & Gt South Rd
Auckland
p: 09 520 1737
10% on kits and modelling supplies



TOYWORLD

Toyworld Henderson
56 Railside Rd, Henderson
Toyworld Westgate
1 Fernhill Dve, Westgate

15% Off the normal retail price on:

- All models and modeling accessories
- All Hornby
- All Siku
- All Schleich & Collecta figures and accessories
- All Meccano
- Lego (Excludes Lego Mindstorm's they will be 10% if available as most have already been pre-ordered)

(Note: not in conjunction with any other promotion)



Merv Smith Hobbies

27 Davis Crescent
Newmarket
Auckland

10% off most items on presentation of IPMS Auckland Membership Card.

Avetek Limited

Gwyn and Christina Avenell
28 Lauren Grove, RD 2, Pakura,
Auckland 2582, New Zealand.

p: +64 (09) 298 4819,
m: +64 (0)27 343 2290
e: aveteknz@gmail.com

www.avetek.co.nz
New Zealand Master Agents for:

Auszac ECO Balsa • Bob Smith Industries - Cyanoacrylates and Epoxies • Airsail International Kitsets

New Zealand Motorcycle Show 2018

IPMS Auckland had a stand at this event held at the ASB Showgrounds over the weekend of 24-25 November. Here is a selection of images from that show for the benefit of those who could not attend. Thanks to Mike Maran for organising our stand and to Peter Harrison and Barry Burton for helping out. Peter also supplied the photos. All three are pictured below along with Jen Bainbridge from the Rock Radio station. Following is Mike's summary of the weekend.

The NZ motorcycle show had about 6000 public through each day. The IPMS site certainly attracted a lot of attention. We had a constant stream of inquiries and questions about the motorcycles on display. The motorcycles on display were all 1/6 scale Tamiya. It was good exposure for the club. The organizers of the show gave us a complementary site and we will certainly display at next year's show. The site was arranged as an open plan so members of the public could come to talk and watch us assembling the models. The organizers commented that our display was a point of difference than the other motorcycle trade exhibitors. Overall a much more different, central and visible publicity for IPMS.



Below is a picture of Mike Maran with Jack Clay from D6M (Double Six Motorsport) whose first motorcycle was the Honda that Mike happened to have a model of.



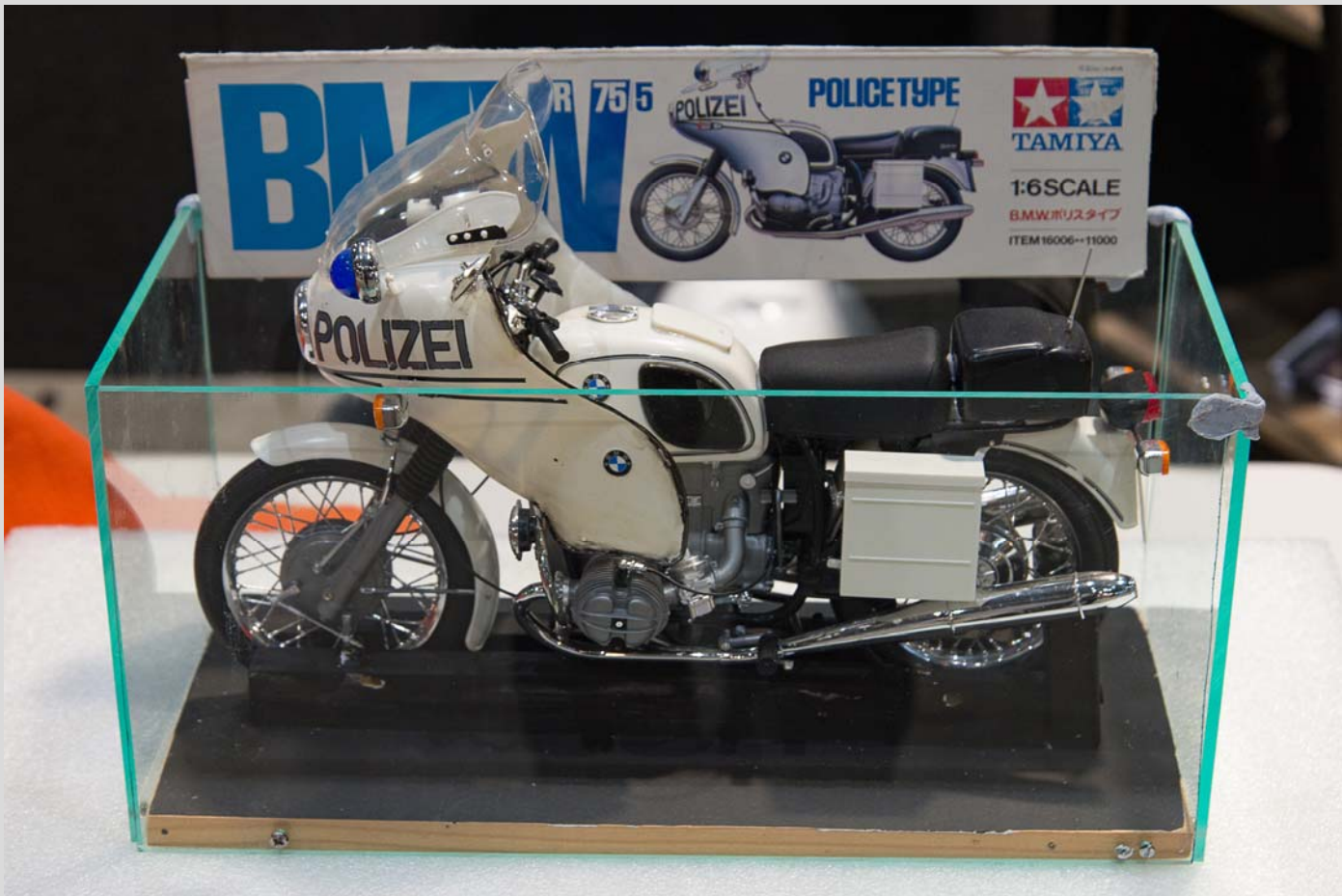





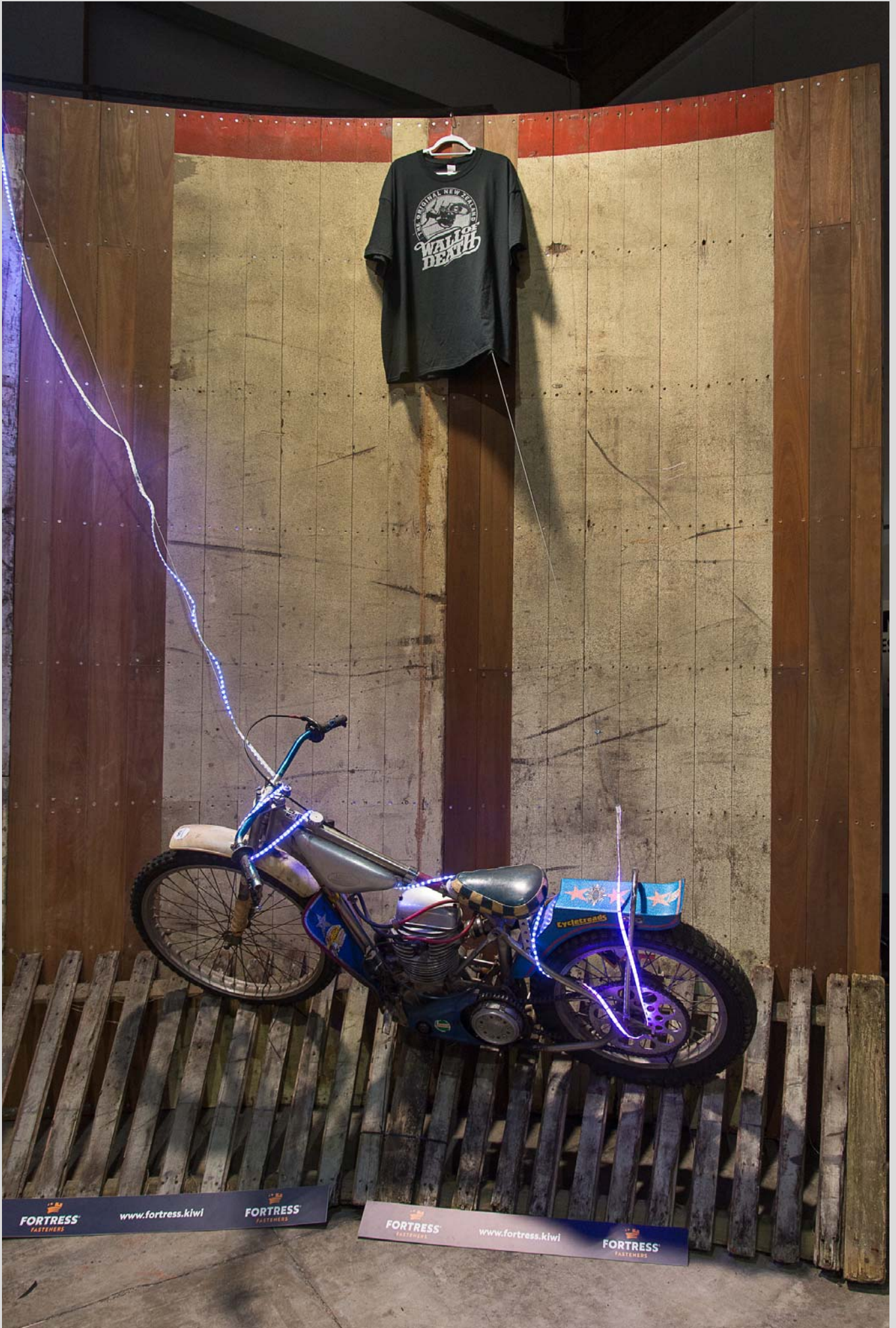









ANATOMY OF THE SHIP



THE BATTLESHIP *BISMARCK*

Complete with more than **660 scale drawings**
and **400 colour 3D views**

Stefan Dрамиński

Book Review By Andrea Birckbeck

"Sink the Bismarck" was the very first war movie I ever saw as a young lad, with my Scottish Father telling me it involved "the greatest naval engagement undertaken by the Royal Navy in the Second World War". The *Bismarck*, one of two Bismarck-class battleships laid down by Nazi Germany's *Kriegsmarine* prior to the outbreak of the Second World War, was fast and extremely powerful, armaments wise. She had a very short career, undertaking only one offensive operation, in May 1941, codenamed *Rheinübung*. Together with the heavy cruiser *Prinz Eugen*, Bismarck sailed into the Atlantic on a mission to block shipping carrying supplies to Britain. Obviously, this was something the British were determined to stop, and so the Royal Navy sent forces to try and intercept the German ships, including the battleship HMS *Prince of Wales*, and the battlecruiser HMS *Hood*. On the 24th of May, at what became known as the Battle of the Denmark Strait, HMS Hood was hit by shells from Bismarck, one of which led to a horrific magazine explosion. Hood sank within 3 minutes of the explosion with the loss of over 1,400 crewmen, having only 3 survivors. The British Prime Minister and former First Lord Admiral of the Royal Navy, Winston Churchill, took the loss of the Hood personally, and launched a relentless search and destroy mission against Bismarck. Together with Royal Navy capital ships and torpedo bombers from the aircraft carrier HMS *Ark Royal*, Bismarck was hunted down and heavily damaged. She was eventually scuttled by her crew and sank on May 27th 1941 with heavy loss of life.

On the hobby front, modelers have been well served for kits of the Bismarck. At the micro end, there have been 1/2000th scale kits by the likes of Heller and more recently Flyhawk. In the two most popular warship scales there has been an avalanche of releases. In 1/700th scale Aoshima, Dragon Models, Flyhawk, Matchbox, Meng, Pit-Road and Trumpeter are among the most well-known firms to release kits, while in 1/350th there are kits from among others Academy Models, Lindberg, Revell and Tamiya. But there are many other kits in multiple scales from yet other manufacturers! For those wishing to add detail to their model of the Bismarck, one can go no further than this tour de force book by Osprey Publishing, the second in their "Anatomy of the Ship" series, a line of naval books initially launched back in the early 1990's by Conway Maritime Press in the UK.



The Conway Press books (also published under the Naval Institute Press label in the USA) came packed to the gills with around 250 pages of superb black and white drawings covering each ship under discussion from bow to stern and hull bottom to the tips of the tallest masts. They were nothing short of brilliant. The two recently published books by Osprey Publishing (the other being "Battleships Yamato and Musashi") are ever BETTER, IMHO, as all the great black and white drawings are now supplemented with full color 3D views of the various sections of the ship! In fact, the Bismarck book is listed as having 660 scale drawings and 400 color 3D views, on 330 pages measuring 10" x 9.5". The paper quality is excellent.

The Bismarck book is divided up as follows:

Section 1

Introduction: a one-page introduction to the book by the author

Technical History: a 22-page written technical history supplemented with well reproduced black and white period photos together with numerous tables covering such things as gun specifications.

History: a 20-page written history of the Bismarck starting with the date Blohm & Voss shipyard was awarded the contract to build her to the hour she sank. Each important date in her short life is listed, together with a description of what transpired on each day, down to covering her last few days almost hour to hour. The text is supplemented by a few nicely chosen period photos, together with a full-page colour map depicting her movements during Operation Rheinübung.

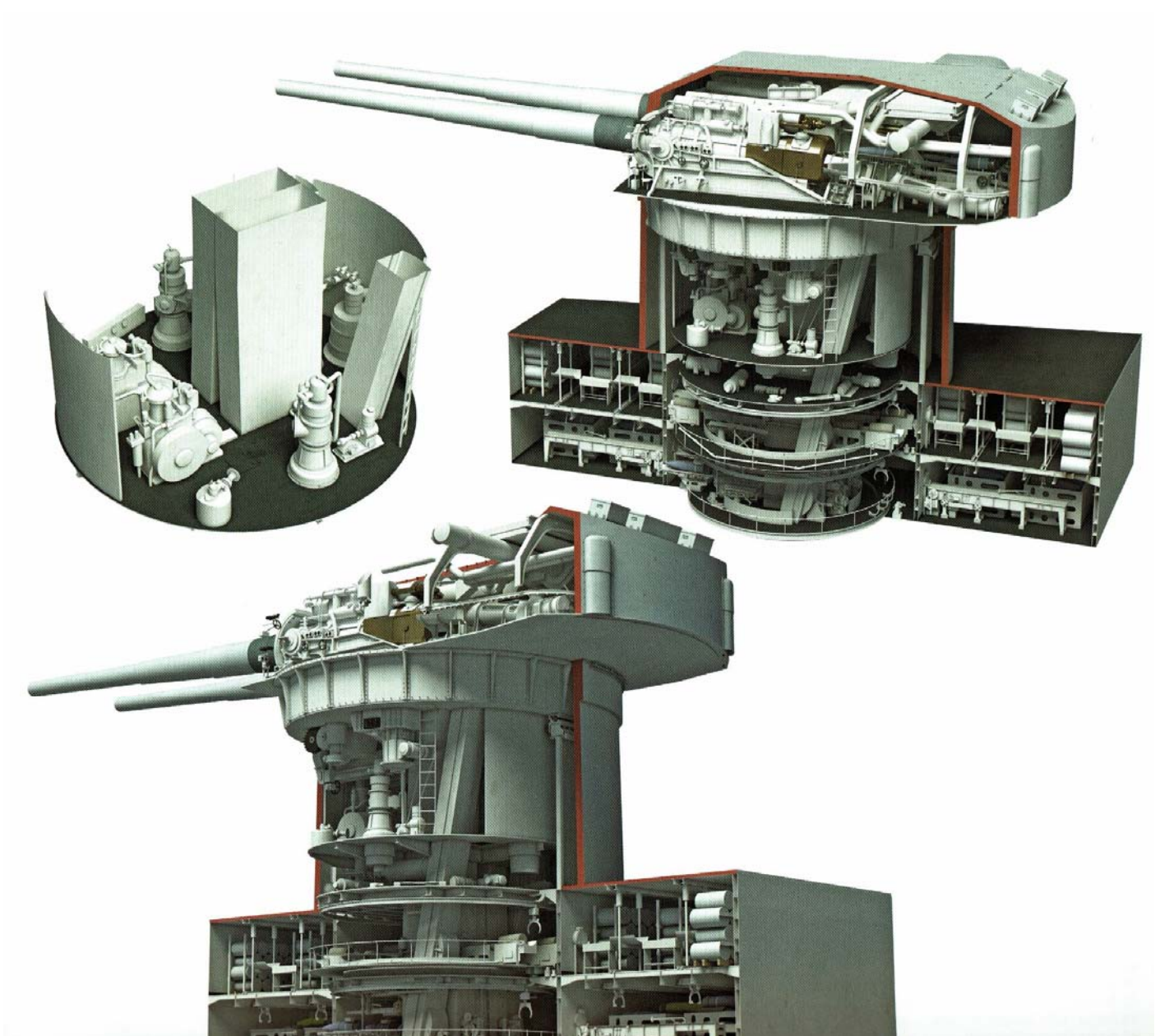

Section 2

Primary Views: Page 50 to 69, showing general view colour profile drawings of Bismarck from various view angles.



Floatplane in a stand-by position – sitting on retractable aircraft cradle. Wings have been unfolded for takeoff.



Section 3

The Drawings

A: General Arrangements: Page 70 to 81, drawn to a constant 1/550th scale, in black and white.

B: Hull Structure: Page 82 to 113, drawn to 1/550th scale, in black and white as well as color. A deck by deck tour of the Bismarck showing what was in the various hull compartments.

C: Superstructure: Page 114 to 171. Another comprehensive examination utilizing B&W drawings as well as 3D color renderings. The detail depicted is incredible, and it covers the various structural changes that occurred to Bismarck from the time of her launch, to the day she sank. Some of the detailed black and white drawings are as large as 1/25th scale down to 1/200th scale.

D: Rig: Page 172 to 189. Mast drawings and diagrams, rigging diagrams, even flag pole details. Also included are diagrams for rigging the lifeboats, various cranes. Amazing stuff.

E: Armament: Page 190 to 249. Is anything missing? Hard to tell, as there is so much detail provided, from 1/125th scale line drawings of the huge main turrets and their 380mm guns, along with color 3D renditions of said guns and turrets. Interior cutaways of the huge turrets. Shell and propellant detail, including color renditions with stenciling details. The same exhaustive details are then provided for the 150mm guns and turrets, the 105mm guns and their mounts, 37mm AA guns and their mounts, 20mm quad guns and mounts, 20mm single guns and mounts, with barrel drawings for these latter in 1/12th scale, while many other details are in 1/25th scale.

F: Fire Control: Page 250 to 269. Details are provided for the Main & Secondary artillery range-finders, artillery fire direction equipment, plus the AA rangefinders. Details in this section also cover the searchlights and ship binoculars.

E5/3 FRONT VIEW
E5/4 BACK VIEW

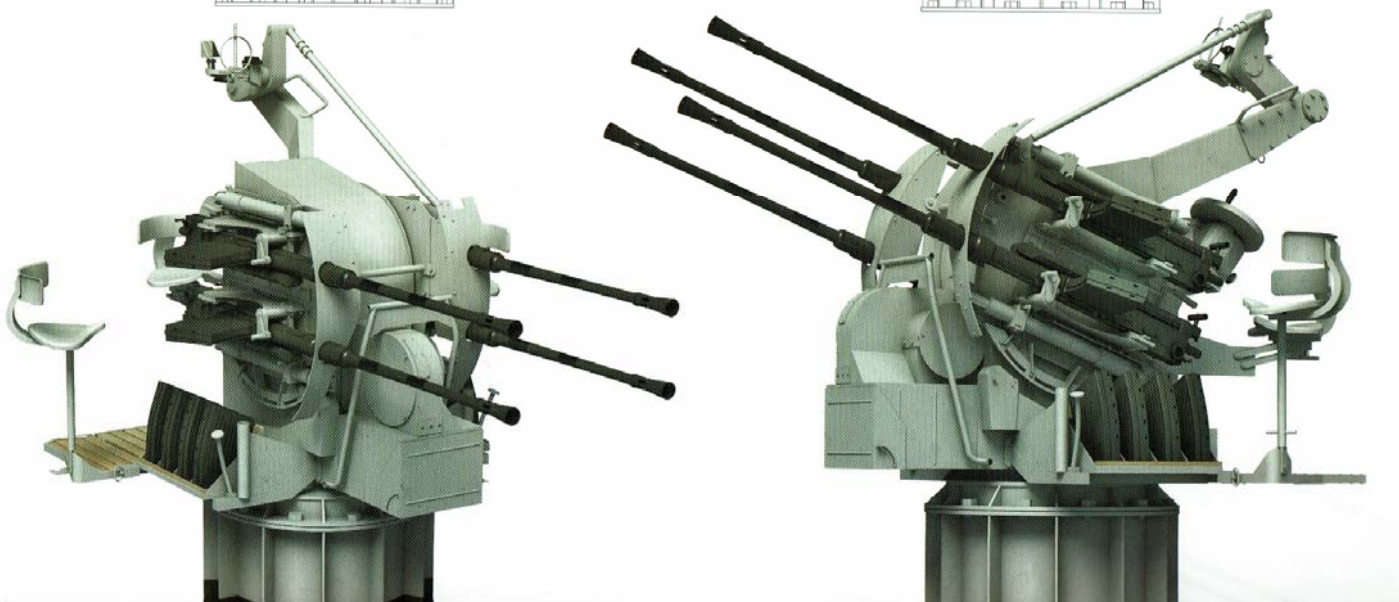
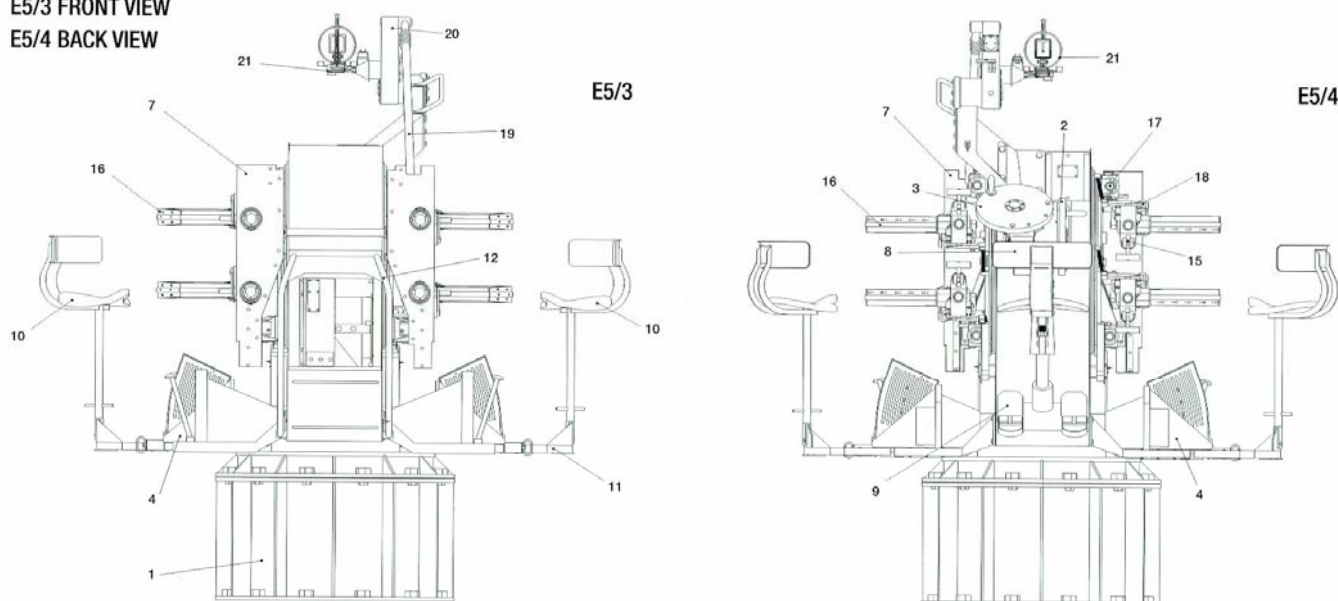

G: Fittings: Page 270 to 307. Hull fittings, anchor chain, anchors, bollards, railings, fire fighting gear such as hoses, rope drums, loud speakers, skylights, wire rope wheels, various hatches and their detail, wall vents, the paravane and its cradle, water tight doors, ladders, lanterns, lockers, signal lamps. In other words: EVERYTHING!

H: Aircraft: Page 308 to 319. The Arado AR 196 float plane, covered by 1/75th scale drawings, along with color and marking profiles. Details are provided showing wings deployed in flight position, as well as with wings folded. Lots of catapult detail drawings and color renditions. Hangar deck details and drawings of the Arado on its catapult.

I: Boats: Page 320 to 327. Motor boats. Row boats. Life boats. Even life raft details. All to 1/75th scale.

J: Other Ships Involved in Operation Rheinubung: Page 328 to 335. A short section covering two other ships involved in this operation: Prinz Eugen and HMS Hood. Various black and white profile drawings done to 1/550th scale, together with colour profiles.

If you have any interest in the battleship Bismarck and modelling it in any of the multitude of scales available, then I would say this would be an excellent book to consult during your build. If you plan on super detailing one of the larger kits, such as 1/350th or 1/200th, then this book must be listed as “essential/must have”. I can’t think of any detail you might wish to add to your model that isn’t covered in this publication. I hope that by looking at the various photographs provided in this review, the reader will be able to see just how super detailed this book is. Run out and buy this book!

My thanks to Osprey Publishing for allowing me the privilege of reviewing this awesome book on behalf of the IPMS USA membership.

Author: Stefan Draminski

Published by Osprey Publishing, Oxford, UK

Price: US\$60.00

ISBN: 978-1-4728-2888-0

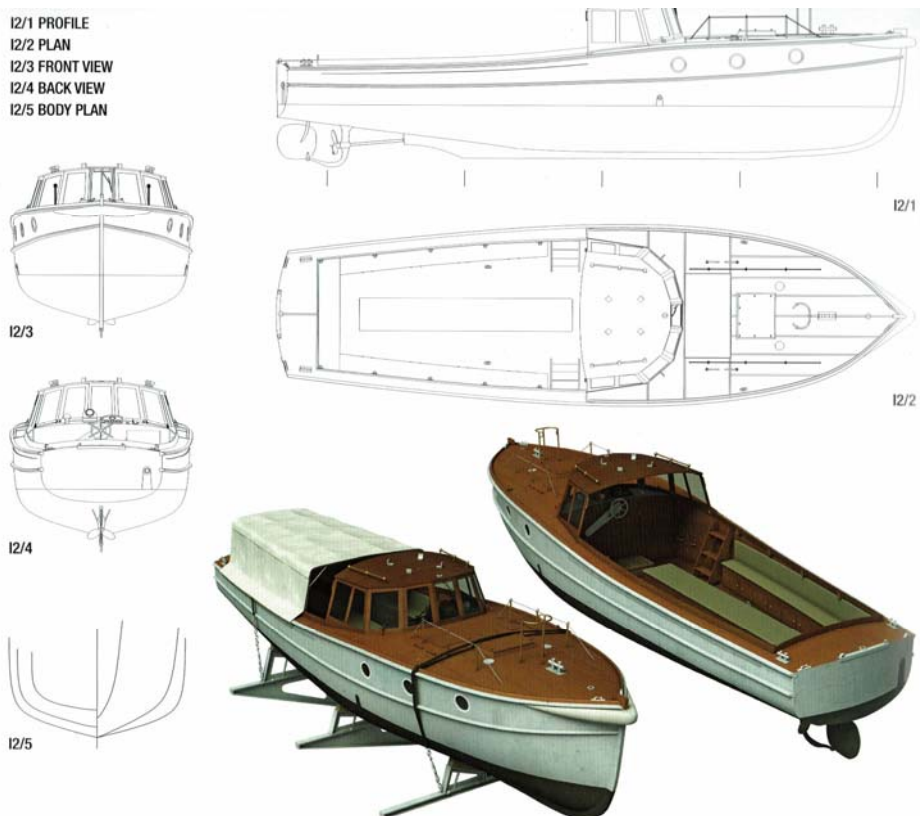

Airfix 1/48 F-51D Mustang (Post War)

By Brett Peacock



Humbrol/Airfix kit #A05136

148 parts on 5 grey and 1 clear sprue trees,

Cartograf Decals for 3 options & Instructions in the “new Airfix” style and booklet.

New Zealand retail price approx \$60.00

This is the second release of the Airfix 1/48 Mustang kit, (previously reviewed in this newsletter) and most of my remarks would be the same for this kit. Basically it is probably the best all glue assembly 1/48 P-51D kit available, and is more accurate than almost any of the competition. Design is thoughtful and innovative without introducing any issues and even a fairly new modeller should not really have any problems making it. But it does require precision when removing stubs a few minute sanding at that point will save hours of trying to remedy the results of skipping that.

The biggest difference is in the Box-art – The P-51D kit had “nice” box art, albeit really somewhat bland. But this –Above- is DRAMATIC box-art!

As to what is new in this box... It has revised Instructions and some very nice new decals (including extra, Swedish Stencilling!)... And there is 1 new sprue, Sprue H which replaces Sprue F from the P-51D kit. Gone are the triple "Bazooka Tube" rocket launchers, replaced by 6 zero-length 6" HVAR rockets and a new, additional, Propellor - a cuffless Hamilton Standard. (see image below – Top - Sprue F, lower - Sprue H)

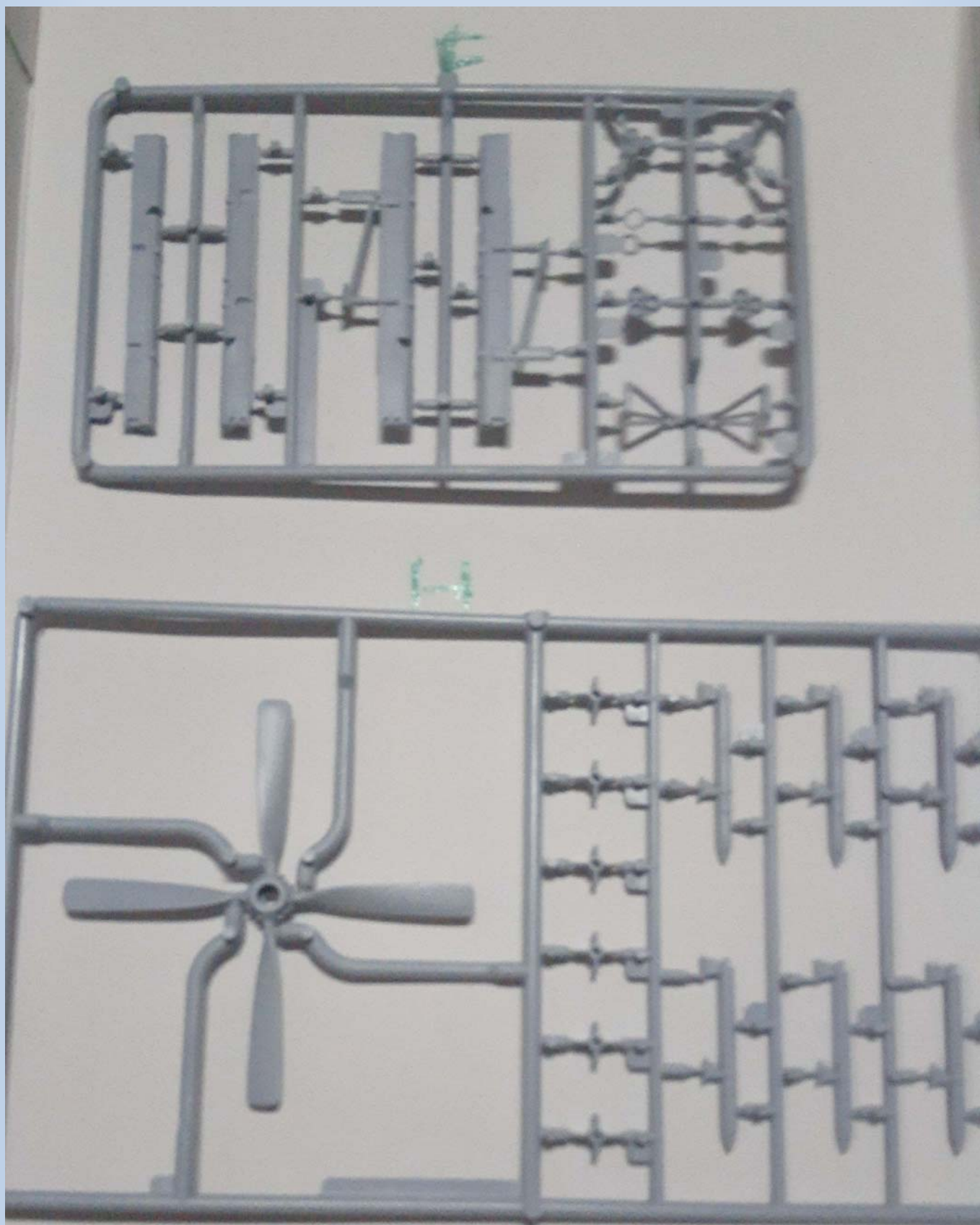

All other parts are the same, and that includes the now unused 108 gallon Paper tanks, just for your spares bin! Unfortunately the 110 gallon metal tanks are still not provided, and they were used for napalm in Korea, the 75 Gallon tanks not used

The three options are:

A:USAF - 67th Fighter Bomber Squadron, Chinhae & Hoengsong Airbases, South Korea, 1952/53. But the USAF legend on the wings is missing and will need to be found by the modeler.

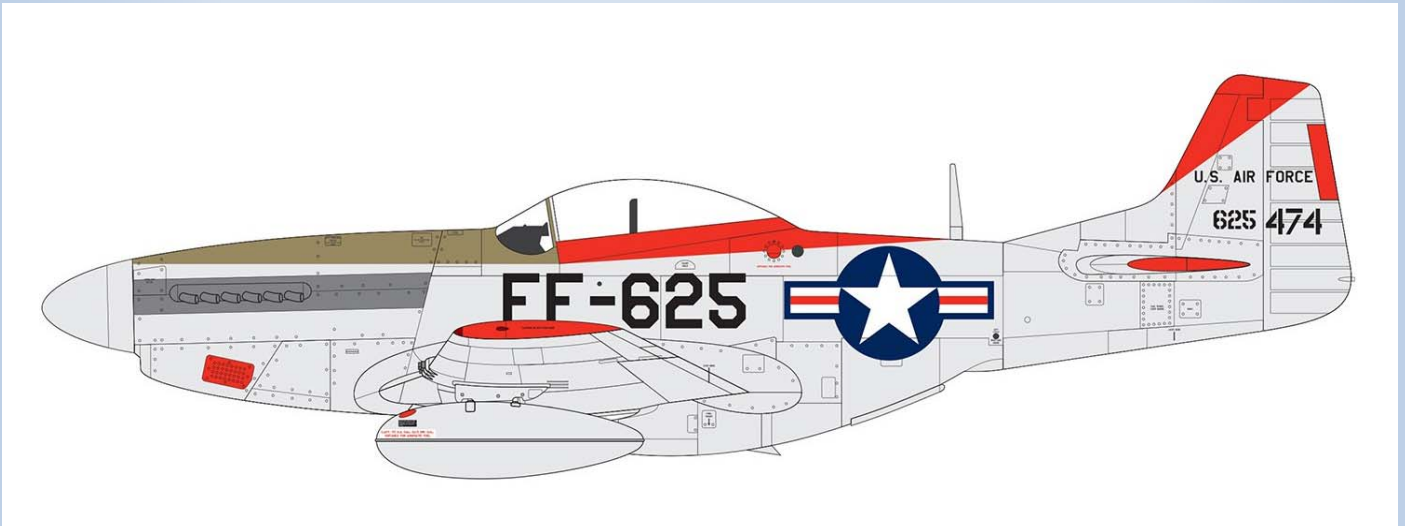

The F51 was retired from USAF service at the end of the Korean Conflict and most in Korea passed on to the South Korean AF.

B: RAAF, No 77 Squadron, Pohang, South Korea, 1951 .

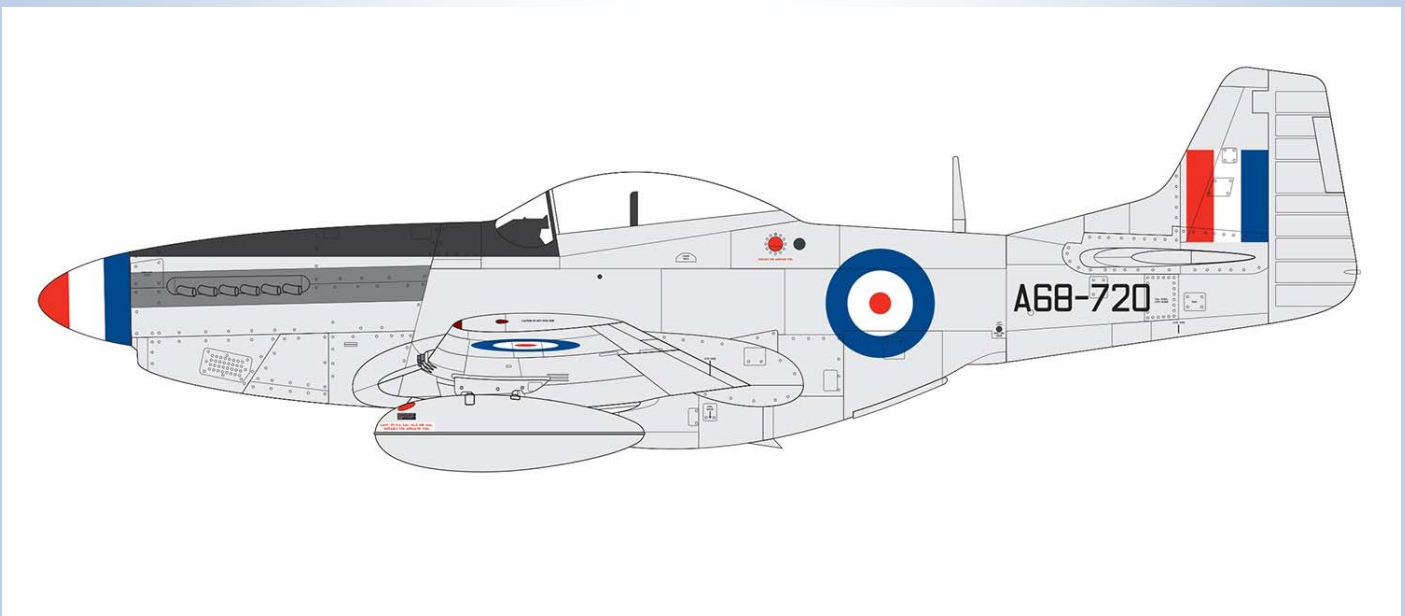

(This RAAF machine has the Cuffless Propellor.)

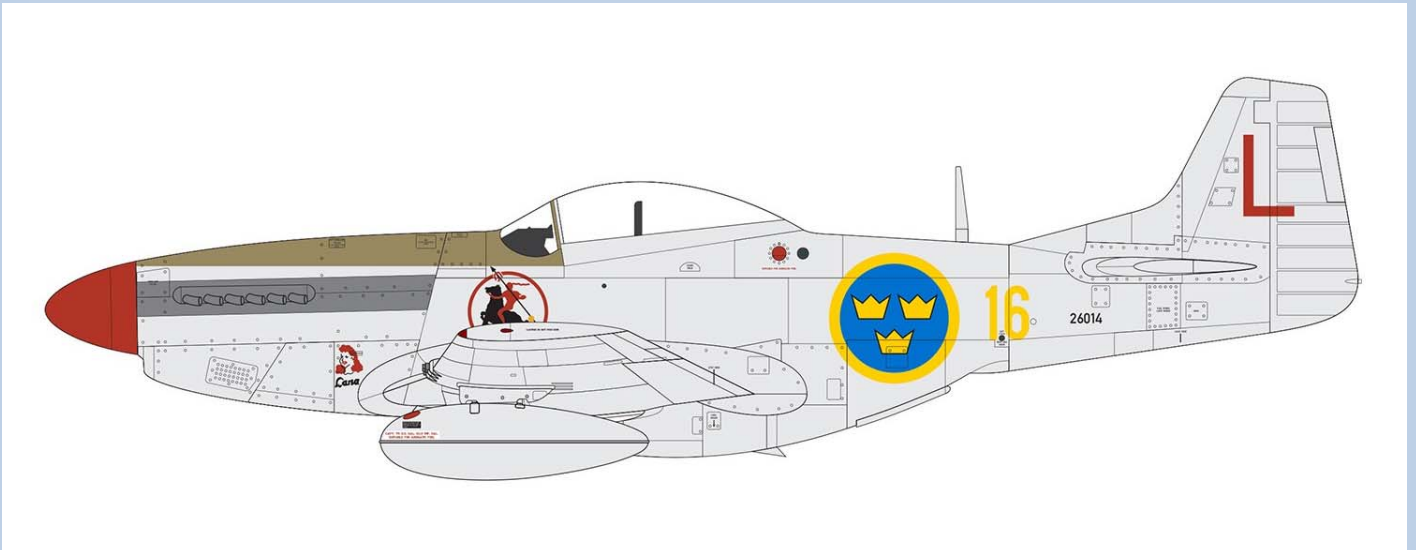

While all 3 options may seem a little bland, there are plenty of Post war options out there, including the 4 RNZAF Territorial Squadrons. As another plus, Airfix correctly call out the differing NMF areas and the Silver painted areas on their colour charts – as can be seen on this example for Option A (the most colourful of the 3.) (In Humbrol, 11 is Chrome Silver and 56 is matt Aluminium. So 11 = Polished metal, and 56 = Silver paint/dope.

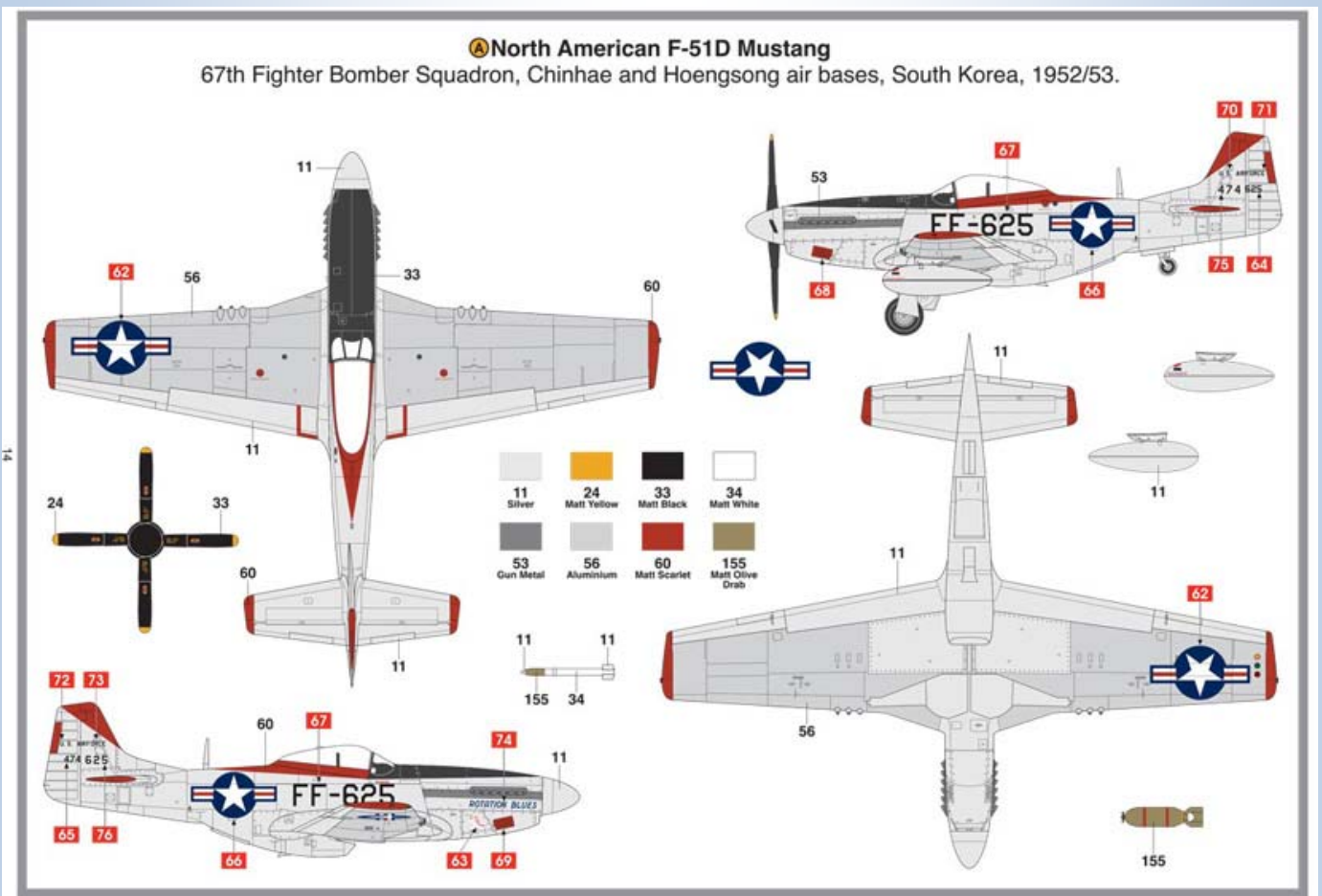

Conclusion: If you model WW2 aircraft, or from the more modern era, this is the kit you want to add to your collection – not that the WW2 box is any less attractive - but this will lend itself to Air-arms from Central and South America to Africa, to Asia and to NZ, and our near neighbour. The last Mustangs to leave any air arm service was during the late 70's, as far as I know. Rush out and buy with confidence! (Even if the kit options are a tad ordinary and the USAF option incomplete!) Airfix have already announced a Mustang IV kit to follow this, with RAF options!

One is the famous “DooleyBird” in NMF -

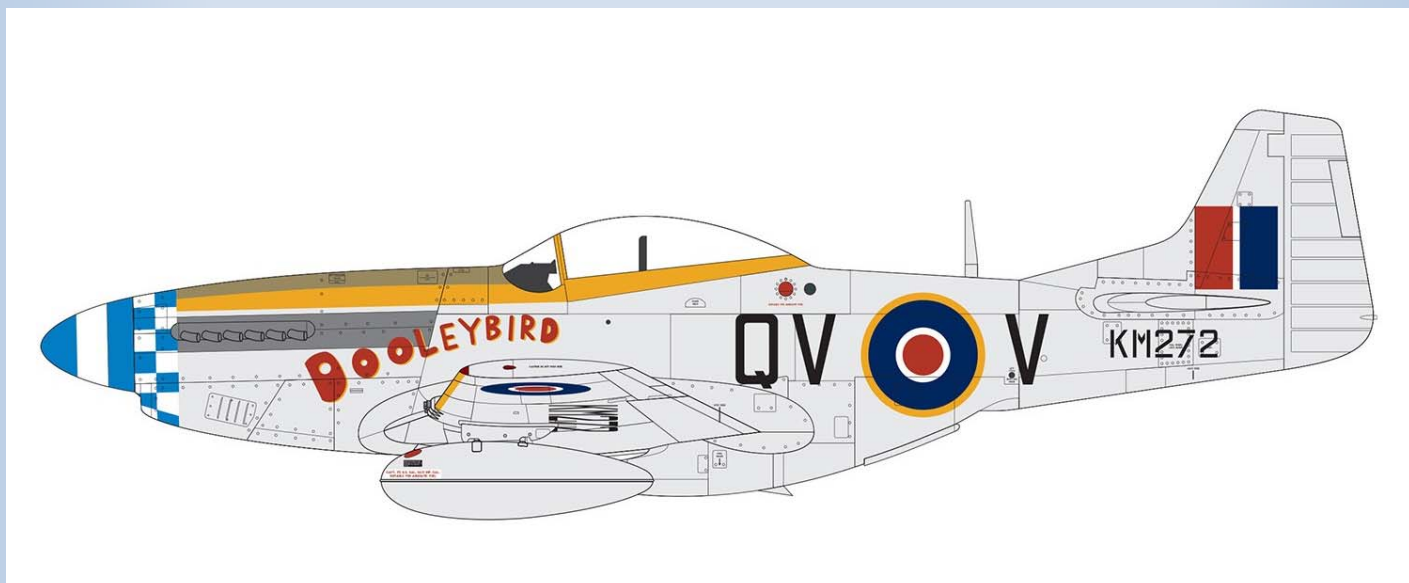

And the Other an Italian front, camouflaged, Aussie Squadron – The Southern Cross gives that away!

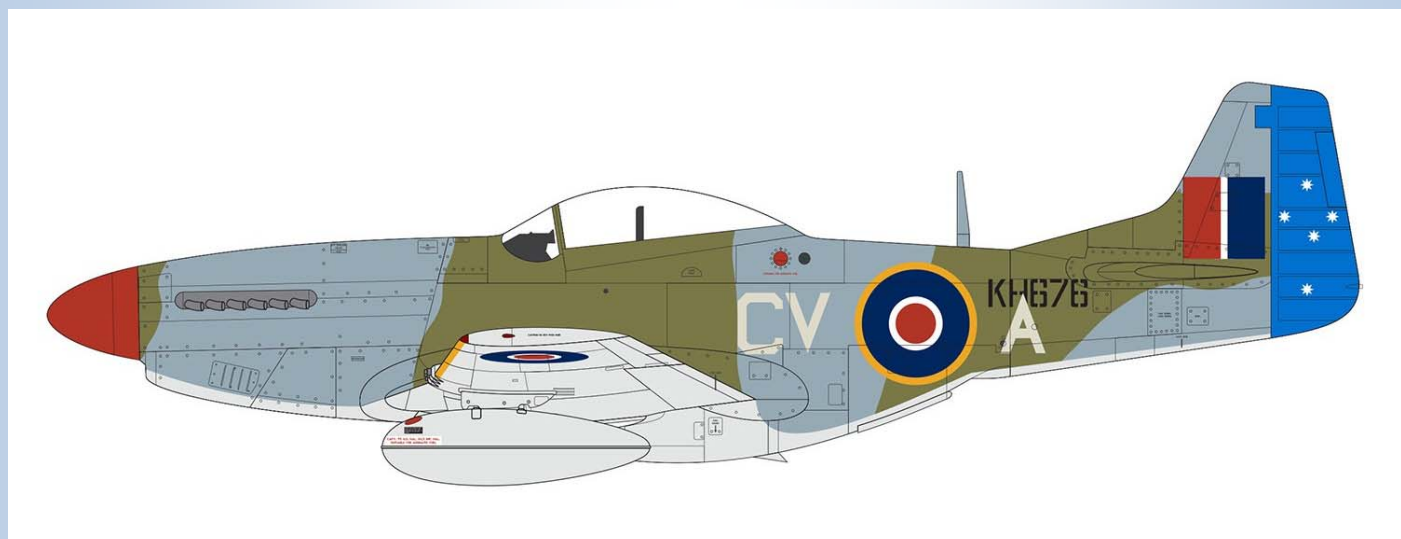

Release of this is still TBA, probably later in 2019

Here is the F-51D Kit Box to look for: You're welcome....



DIY Magnetic Painting Handle

By Lance Whitford

I have long used a home made handle to hold my AFV models during the painting and weathering phases. My setup is simply a piece of dowel with a small 'L' bracket the top. I have a drilled block of wood that the handle drops into when not in use. To mount my models I drill a hole in the hull and either screw or bolt the model to the handle. Recently I came across a review of a magnetic painting handle made by RP Toolz and a light went on. A quick google later I discovered a place that specialises in magnets which also happened to be less that 10min drive from my house. You can order from these guys online as well. I went down and explained my idea and was shown a range of choices. I selected a donut shaped magnet that had the sort of strength I was looking for and bought a couple of those to try. When I got home I removed the 'L' bracket from one of my handles and screwed the magnet on top. The next part of the equation is having something attached to the model that the magnet can lock onto. I gat a suitably large washer from the toolbox and secured this to the interior of my test model with Blu Tak. This worked really well. The model could move around a little but the bond with the magnet was not going to break without determined effort. No more drilling and bolts for me. The following pictures illustrate my original design and the modified magnetic version.

I got my magnets from MAGNETS NEW ZEALAND LTD. www.magnets.co.nz

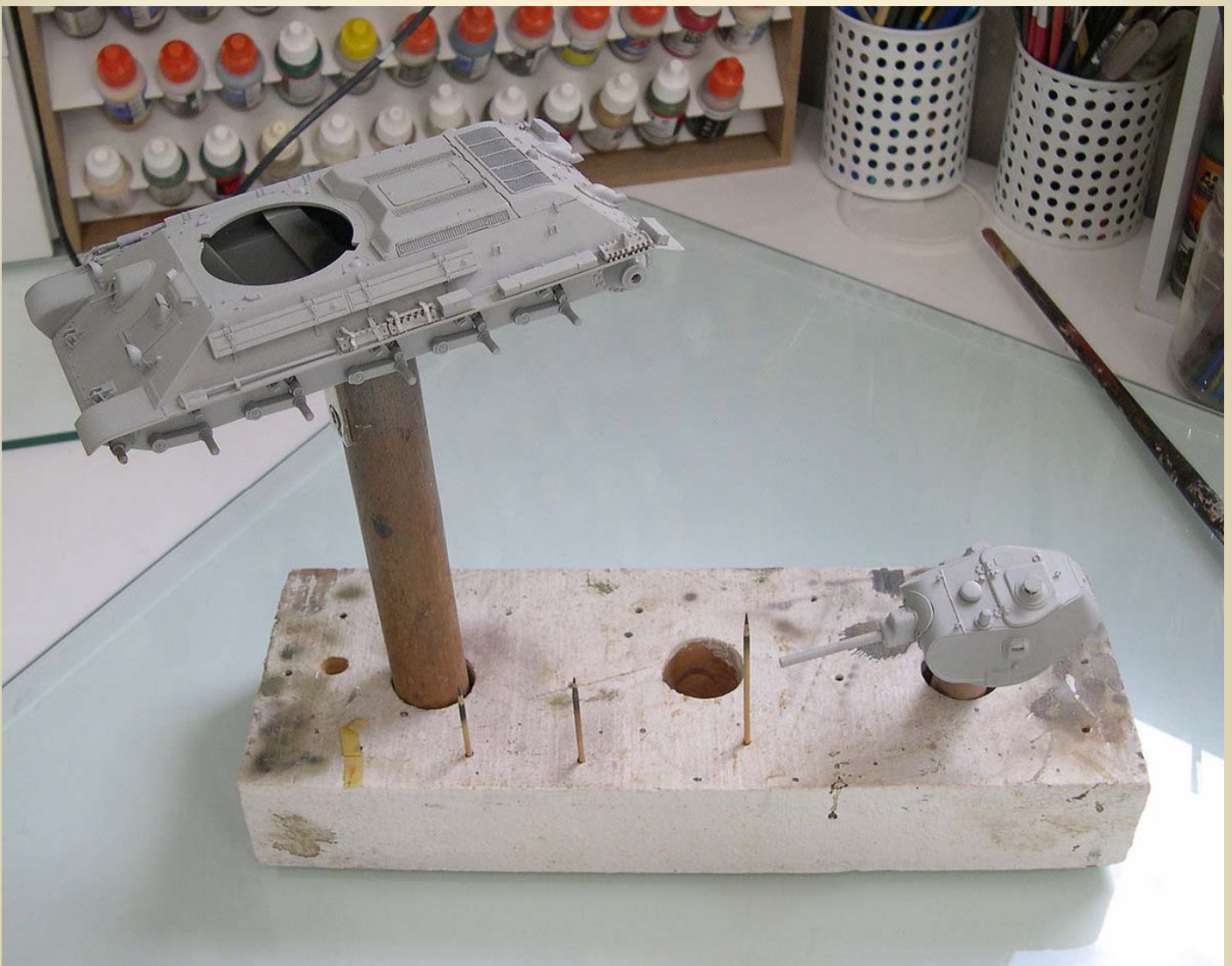



GALLERY

CLUB NIGHT MODELS

Check out our Website gallery for photos taken of models at our monthly meetings

<http://ipmsauckland.hobbyvista.com>



And as usual -check out the IPMS Auckland website as we're trying to keep the content a bit more dynamic. We won't be regurgitating content found on other websites but will provide links to sites we think are of interest to members.

