



Contents

Bulletin Board

1/72 Resin Replacement Tracks
by OKB-Grigorov:

'REFLECTIONS ON RESEARCH'

1/35 Resin Drive sprockets for Early
T-34's by OKB-Grigorov

On the table at our December meet-
ing

NEXT MEETING

7.30 pm Tuesday 19/12/2023

Royal Oak Bowls

146 Selwyn St, Onehunga

COMMITTEE

Chairman - Craig Sargent Dave Fish
Secretary - Brett Peacock Lance Whitford
Treasurer - Mark Robson

EDITOR: Lance Whitford
e: lancewhitford@hotmail.com

EMAIL: ipmsauckland@gmail.com
WEB: ipmsauckland.hobbyvista.com
YAHOO:
groups.yahoo.com/group/ipmsauckland

FACEBOOK:
[https://www.facebook.com/groups/
ipmsauckland](https://www.facebook.com/groups/ipmsauckland)

From the Editor

Happy New year all. To start the year off we will be asking those who have chosen a black and white subject and have the kit (started or not) to bring that along to the January meeting.

As promised at the December meeting, we be using an online form to capture the wild estimates that members make of the number of models you plan to complete this year. There is a page later in this newsletter with all the details of how to access that. The questions are basic, just name, email address and the estimate of models you expect to completed.

December Competition Winner

We had a fantastic turnout of models in December. Congratulations to Andy Chui whose B-25 garnered the popular vote for the favorite model on the table. Thanks to Kotare for donating the prize of a 1/32 Spitfire Mk1 Early.



BULLETIN BOARD

NEW MEMBERS AND SUBS *** 2023/24 NOW DUE *******

Subs for 2023/24 now due -see below for club account details or see the club secretary at the next club meeting. The Interim account to use is shown below

Membership	Description	Cost
Full	Living in the Auckland	NZ\$45
Out Of Town	Living 75km or more from	NZ\$30
Junior	Same rights as full membership for those under	NZ\$25

***Please use this account
until further notice
03-0114-0006259-02***

EVENTS

CLUB NIGHT EVENTS

**IPMS Auckland Meet on the
third Tuesday of each month at
7.30pm**

**Venue: The Sports Lounge
Royal Oak Bowls
146 Selwyn St, Onehunga**

**16/12/23
January**

Bring your entry for the 2024 Black and White theme build. The model could be still in its box, part completed or finished already. Tell the group all about it.

Nothing to report this month

BULLETIN BOARD

CLUB SUPPORT

The following retailers have kindly agreed to offer IPMS Auckland club members a discount on their purchases upon presentation of their current IPMS Auckland Membership card.

The discount only applies on selected product lines and remains at the discretion of the retailer.



Modelair

349 Dominion Road
Mount Eden
Auckland
p: 09 520 1236



Cnr Market Rd & Gt South Rd
Auckland
Ph: (09) 520 1737

10% on kits and modelling supplies

Constellation
HOBBIES

Unit 5/1 Greenwich Way,
Unsworth Heights,
Auckland.

Ph: (09) 441 3562

10% on kits and modelling supplies

Email:

info@constellationhobbies.co.nz

Web:

www.constellationhobbies.co.nz



Merv Smith Hobbies

27 Davis Crescent
Newmarket
Auckland

10% off most items on presentation of IPMS Auckland Membership Card.

Avetek Limited

Gwyn and Christina Avenell
28 Lauren Grove, RD 2, Pa-
pakura,
Auckland 2582, New Zea-
land.

p: +64 (09) 298 4819,
m: +64 (0)27 343 2290
e: aveteknz@gmail.com

www.avetek.co.nz

New Zealand Master Agents
for:

Auszac ECO Balsa • Bob
Smith Industries - Cy-
anoacrylates and Epoxies •
Airsail International Kitsets

2024 Model Completion Estimates

This year our 2024 model completion estimates (aka rash statements register) go online.

Follow this link to access the entry form shown below : <https://forms.gle/5ZnuyYMWrxu6vqQo6>

Just fill in your email address, name, and the number you expect to complete then click submit.

If you would like a confirmation email then slide the 'send me a copy of my responses' indicator right to turn it on



IPMS Auckland members 2024 build predictions

[Sign in to Google](#) to save your progress. [Learn more](#)

* Indicates required question

Email *

Your email address

Enter your name here

Your answer

How many models do you expect to complete in 2024 *

Enter the number here

Your answer

Send me a copy of my responses.

Submit

Clear form

Never submit passwords through Google Forms.



reCAPTCHA
[Privacy](#) [Terms](#)

This content is neither created nor endorsed by Google. [Report Abuse](#) - [Terms of Service](#) - [Privacy Policy](#)

Google Forms



WARBIRDS ON PARADE — ARDMORE NZ — 2024

SUNDAY MARCH 10th
www.nzwarbirds.org.nz

ARDMORE
AIRPORT



NZ WARBIRDS
ASSOCIATION



FUJIFILM
Value from Innovation



We are back for 2024!

Join us for a day of high octane action, aerobatics, formation fly pasts and aerial displays. See New Zealand's aviation heritage where it belongs – in the sky!

WARBIRDS ON PARADE - Sunday 10th March 2024
Ardmore Airport, Auckland, New Zealand.

Whats on parade?

- »Flying and static WW1, WW2, classic and jet aircraft
- »Classic cars and military vehicles
- »Warbird restoration projects
- »Trade and educational displays

Gates open at 9:00am followed by flying display slots at 10:30am | 12:30pm | 2:30pm

Merchandise and refreshments will be available.

The perfect outing for the whole family!

Tickets available through iTicket.

Follow us on Facebook or visit our website www.nzwarbirds.org.nz or scan the QR code to keep up to date with all the latest details.



Photo Below: ©Gavin Conroy
Photo Reverse: ©Gavin Conroy

1/72 Resin Replacement Tracks by OKB-Grigorov:

By Mark Davies

- [S72042 Pz.III/IV 40cm Type 1](#) (€10.00)
- [S72259 Leopard 2](#) (€15.00)
- [S72316 Leopard 1 Late](#) (€15.00)
- [S72319 Pz.III/IV Type 8](#) (€10.00)
- [72420 Leclerc](#) (€10.00)

OKB-Grigorov's tracks offer superior detail to most kit items and, on an initial assessment, would appear to offer close to the convenience of vinyl tracks over sometimes fiddly link & length kit tracks. They also eliminate the risk that vinyl tracks, supplied with some kits, have of dissolving the styrene wheels or falling apart with age. They also often provide patterns, types, or widths not offered by kit tracks, enabling either greater accuracy or alternate versions to be modelled.

However, resin tracks are not always as easy to fit as is often assumed. Generally, the smaller the vehicle, especially its drive-sprockets and idlers, the trickier it can be to fit resin tracks. This is because small radius bends need some application of heat to assist the track in conforming to the track run as, without warming, the track tends to snap.

One method I have used to heat resin tracks is the judicious use of a hairdryer, although it is very easy to misjudge its use and overheat resin tracks with disastrous results. The other is hot water (I limit the heat to one I can tolerate immersing my hand in). Again, if too hot, disaster will result. With either method I try to curl the track around the model's running gear, or a balsa wood form that conforms to the internal dimensions of the track run – Close is good enough as precise fitting is done after forming. Sometimes simple manipulation of the tracks by hand when warmed will suffice. Take care not to bend or crush delicate guide teeth whichever method is used. A bowl of cold water to immerse the heated track in can speed the track's cooling and almost instantly lock in whatever curvature you have caused it to assume.

I have found that resin tracks sometimes will not fit around kit drive sprockets. This is due to small variations in track segment size and pitch. Sometimes, as with the three Cold War tank sets reviewed here, resin drive sprockets matched to the resin track's pitch are included.

OKB-Grigorov's tracks are very good quality and, having bought many of their accessories and kits in the past, I am happy to recommend the tracks reviewed here. They are best ordered with as many other items as you can justify, to spread the fixed postal charge as thinly as you can. Thanks to OKB-Grigorov for the review samples.

S72042 Pz.III/IV 40cm Type 1

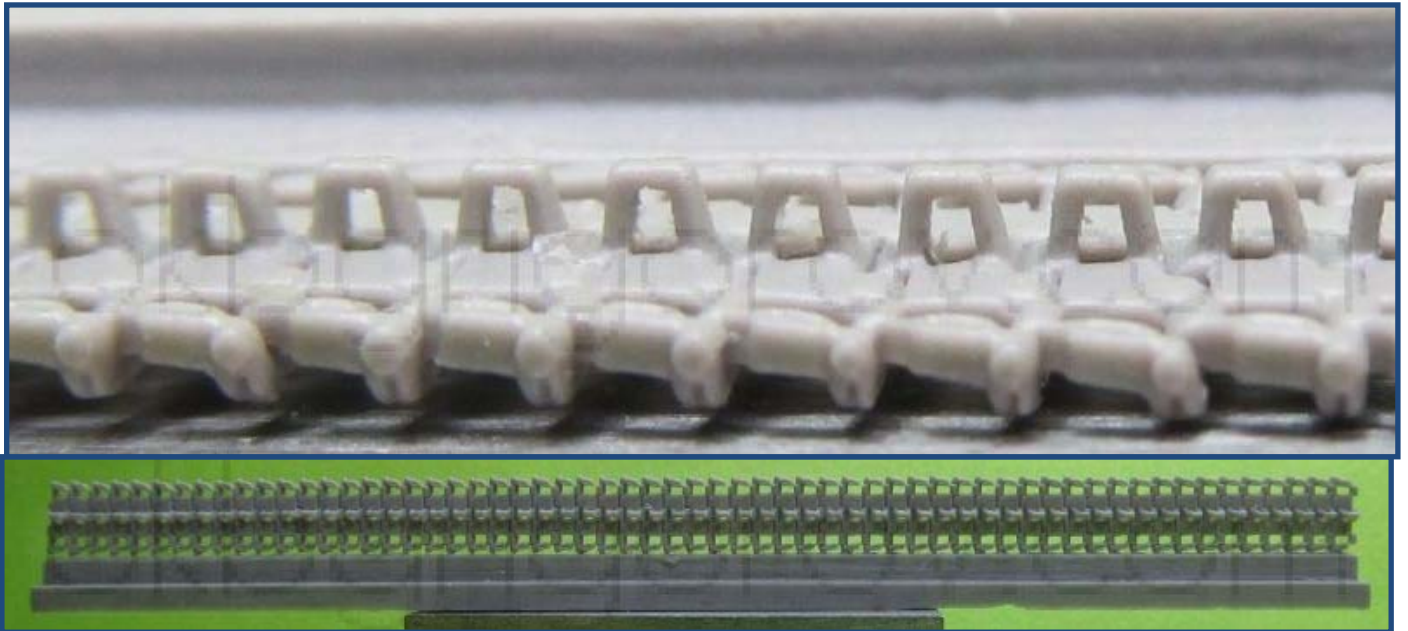
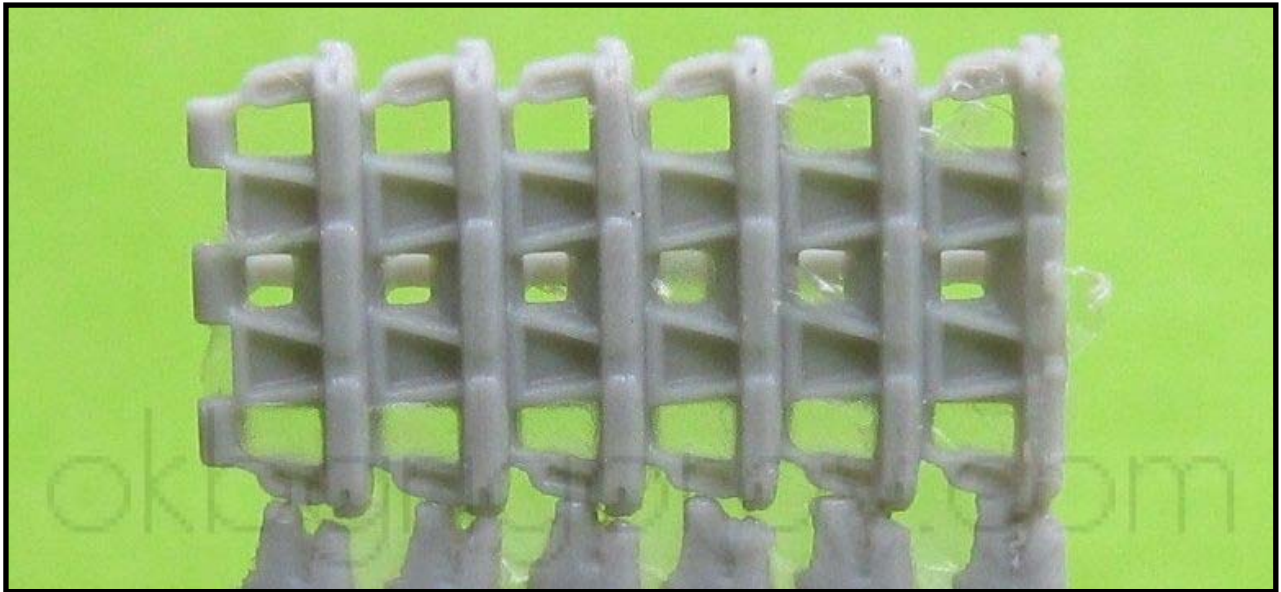

S72319 Pz.III/IV Type 8

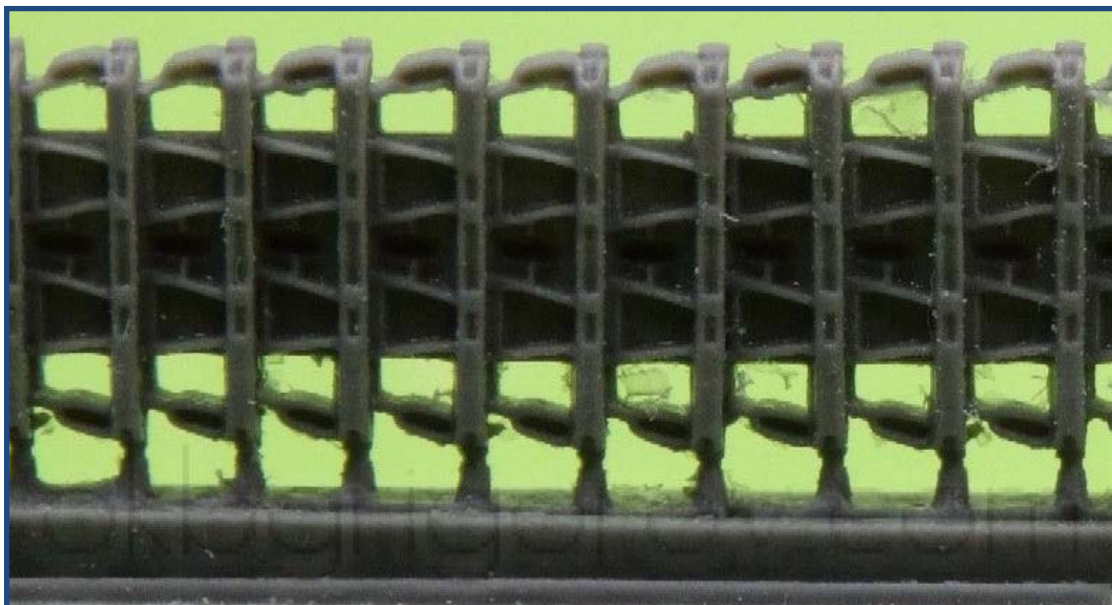

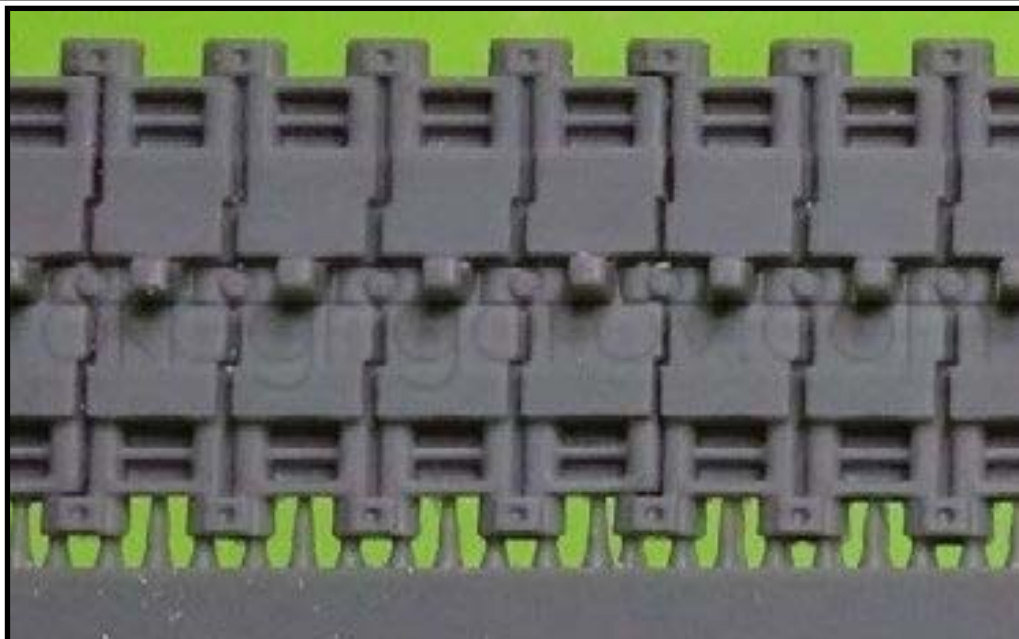
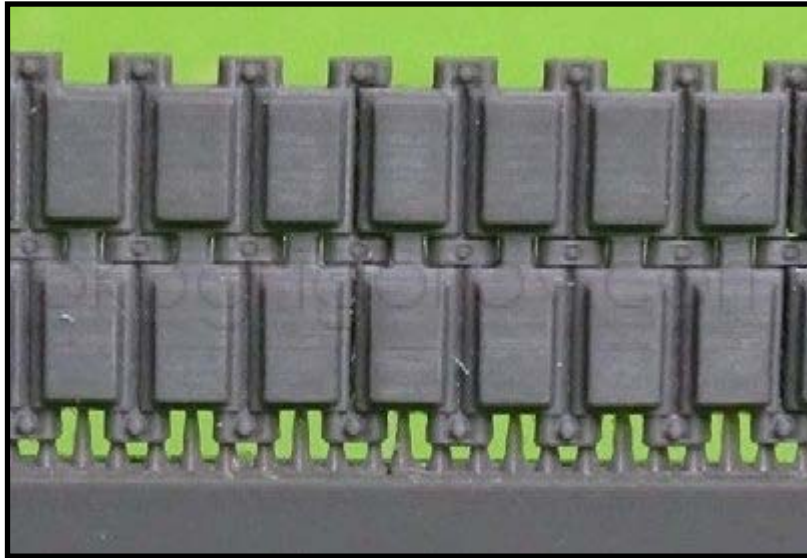

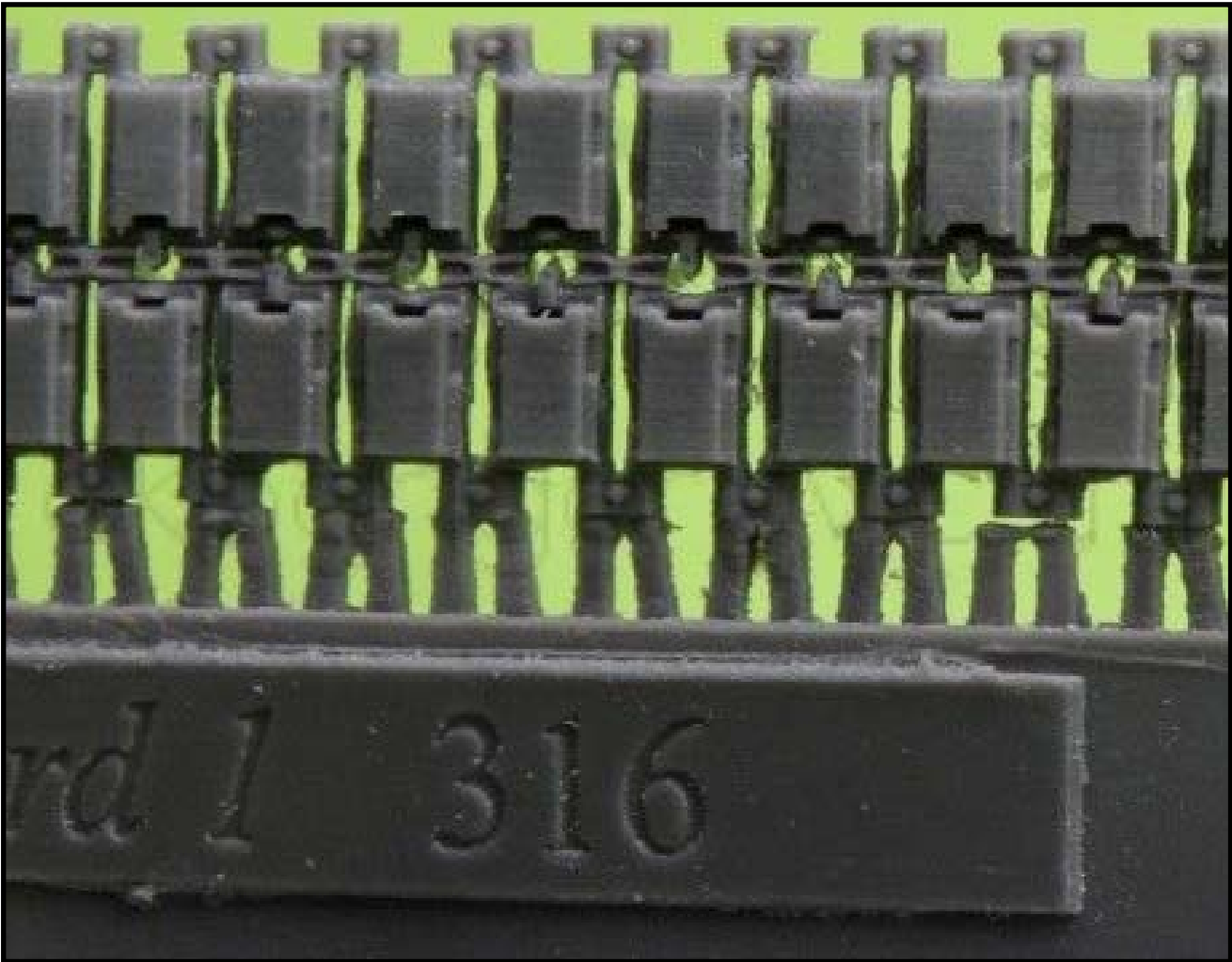
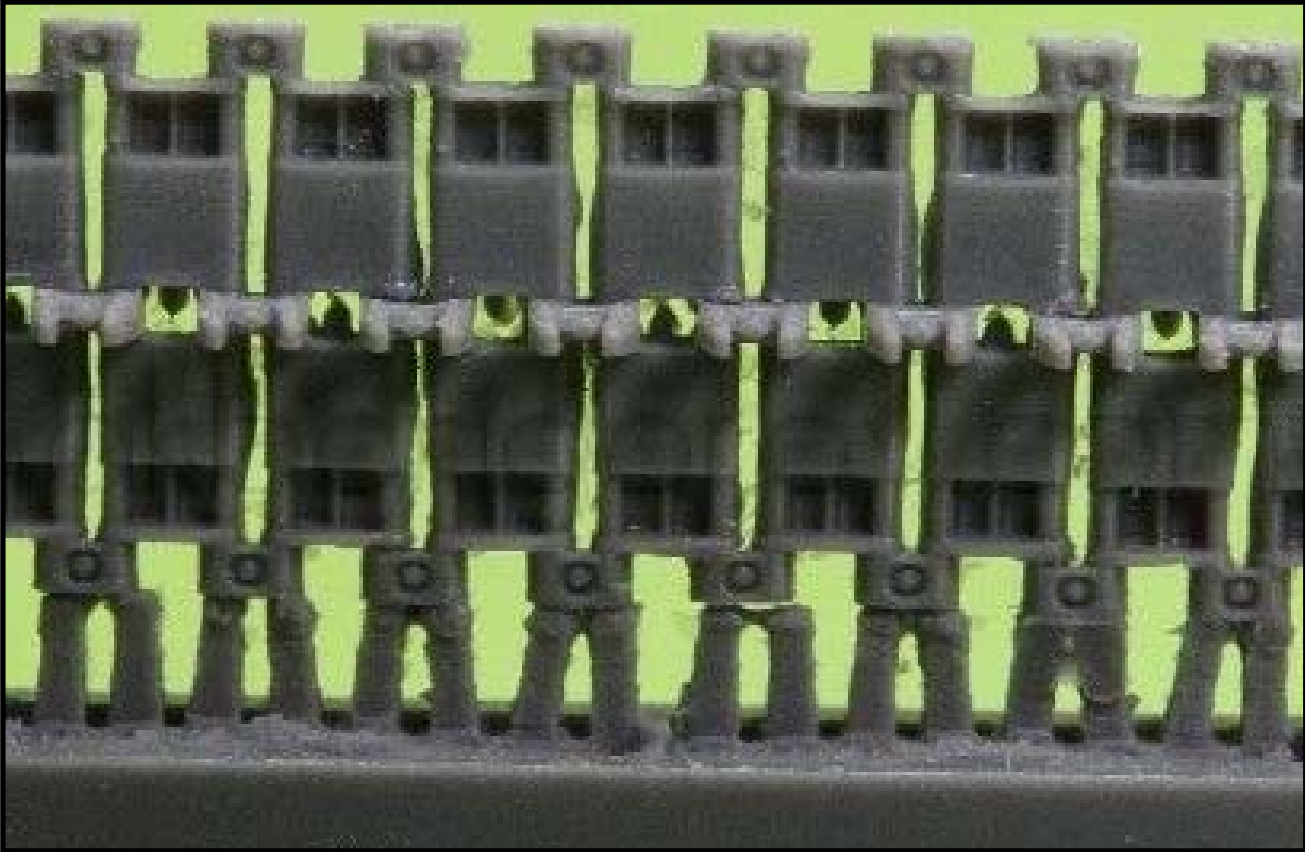

'REFLECTIONS ON RESEARCH'

By Pete M.

The above headline is a 'borrow' from the original editor of our now long defunct IPMS New Zealand/Auckland magazine 'Scale Dimensions', Paul Tibbutt.

This article came about when I was trying to decide on a subject for our upcoming Black/White group build, and hopefully something reasonably simple and straightforward and to hopefully regain my dormant modelling mojo back!

I had decided to build the A6M3 Type 22 (Zero) that was brought back to New Zealand after the war, and now resides in the Auckland War Memorial Museum. For more on this see my website page at:

<http://rnzaf.hobbyvista.com/zero.html>

I was going to do it in the 'surrender' scheme of overall white with green crosses as found by the RNZAF when they learned of its presence on southern Bougainville, so dug back through my files for photos I have saved of it in this scheme. Looking at some of the high resolution photos I'd saved from the Air Force Museum Of New Zealand site showed up something I had never noticed before, or had seen any comments about...the cockpit canopy had only been painted white on the port side, and the starboard side remained in the original dark green!

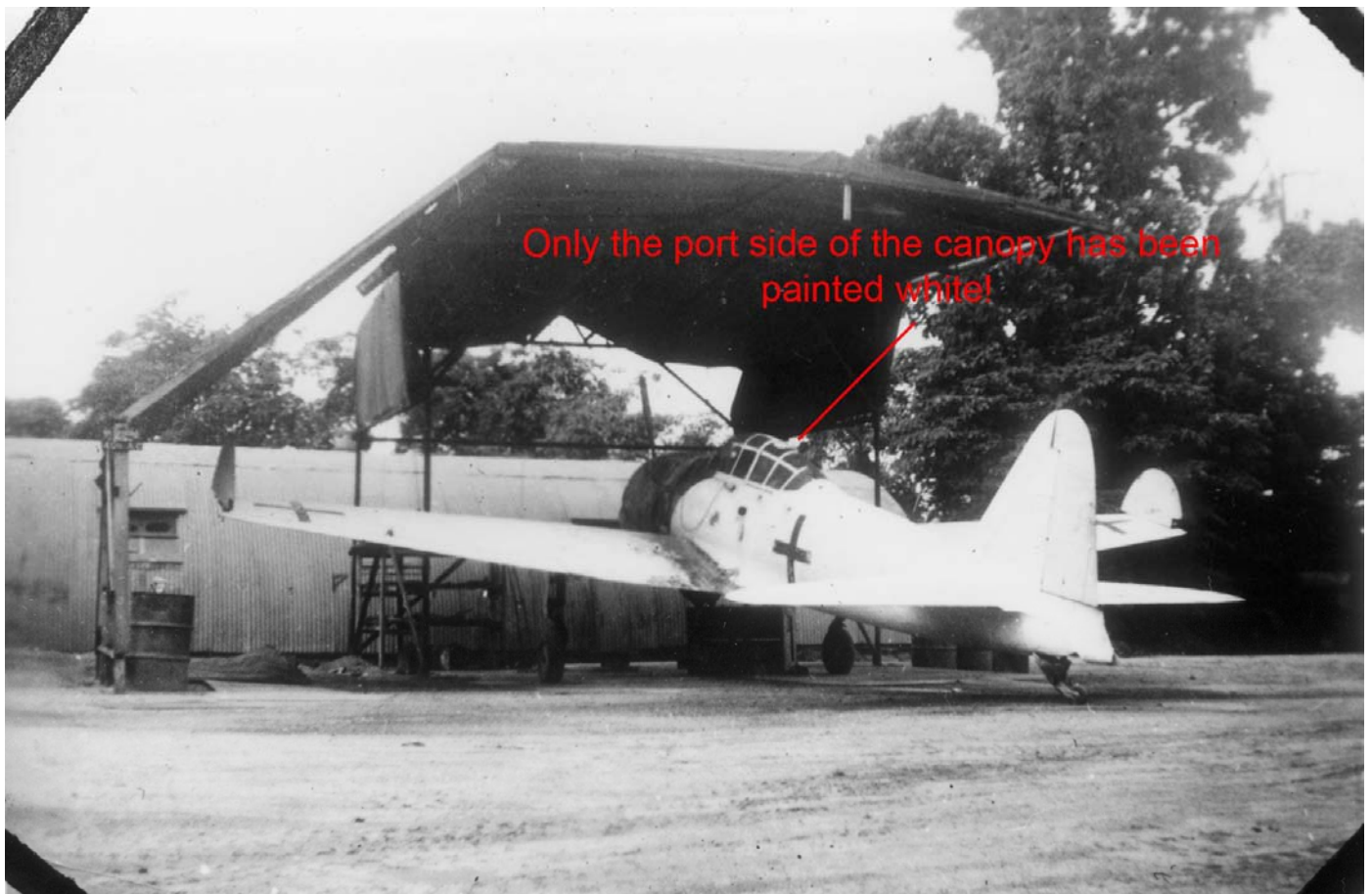



Hmm....double checked, and it's the same in all photos of this aircraft taken on Bougainville.

The next item to sort out was the colours of the oddly done anti-glare panel colours on the cowling. Once again, a close look at one of the museum's photos shows that this appears to be two different colours, and I have deduced that the engine cowling would have still been in the standard blue-black as originally painted at the factory, and behind that and the starboard canopy side in the standard IJN dark green.



I was lucky to find that I did actually have the correct 1:48 scale model in my stash (the Hasegawa kit JT110), and as a bonus, included in the box was the KMC A6M3 (type 22) update set 48-4002! Lots of lovely resin and PE cockpit upgrades, resin and PE folding wingtips and a couple of other items such as PE cowl flaps and resin ailerons and flaps. I have got into the habit of purchasing such items when they are first released, one never knows whether they will be in production for long, or how long before they become the proverbial 'chickens lips/rocking horse sh*t).

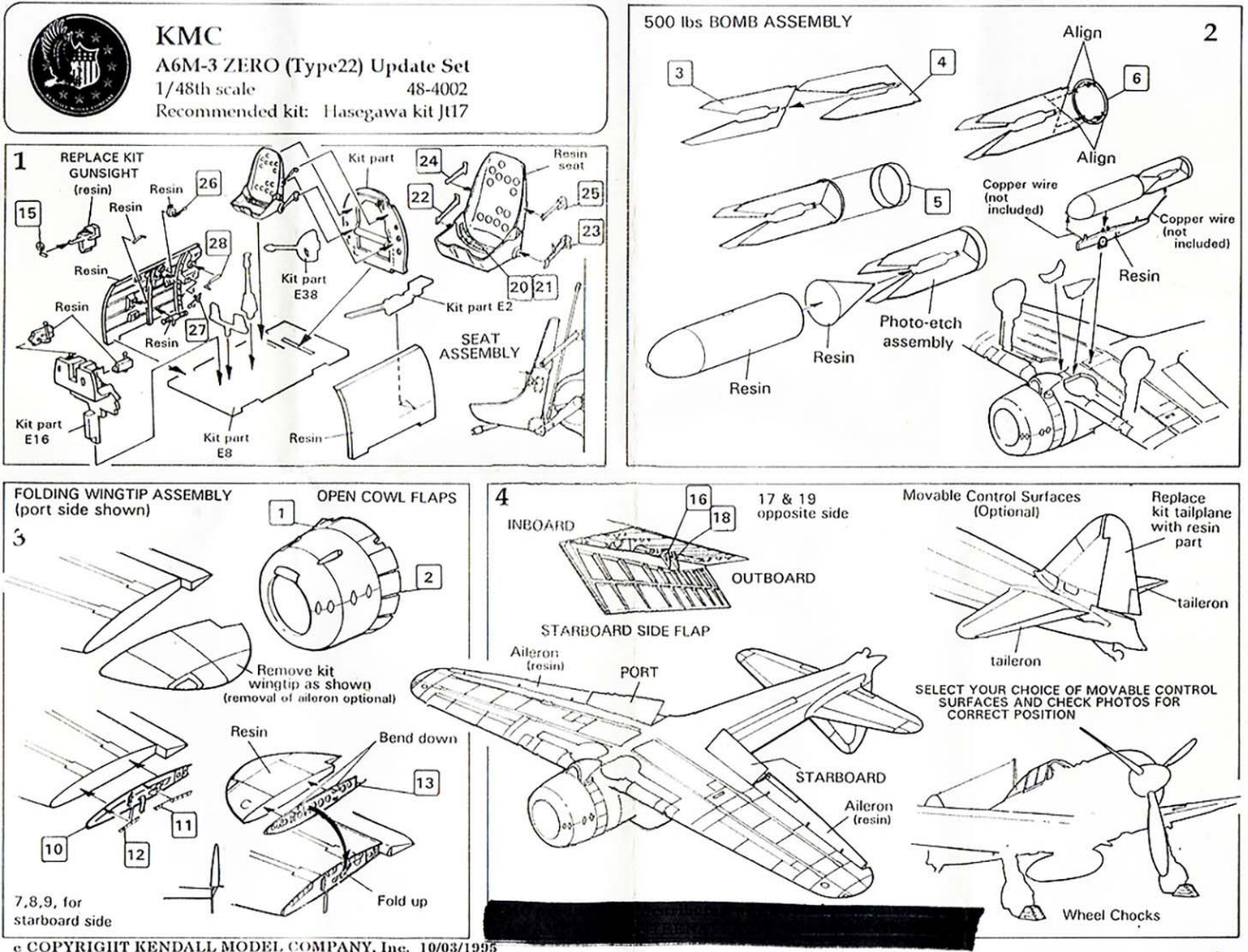

It's still going to take a bit of work as it will firstly require finishing in the original 'factory' scheme, then roughly whitewashed with the green crosses. Should exercise all of my latent skills eh-what!

1/35 Resin Drive sprockets for Early T-34's by OKB-Grigorov

By Lance Whitford

OKB Grigorov has an excellent reputation in the 1/72nd scale upgrade space, and I did not realize that they had some upgrades available in my preferred 1/35th scale. When the club received some OKB products for review recently they included a couple of sets of replacement sprockets for a 1/35th scale T-34 and I picked those up for this review. The sets are S35004 – Sprocket wheel for T-34 Model 1940 Type 1 and S35004 – Sprocket wheel for T-34 Model 1940 Type 3.



OKB
Scale
1/35
S35010
Sprocket wheel for T-34
mod.1940 type 3



The T-34 had innumerable detail changes throughout its long production, including many variations in the running gear. Some variations were aimed at simplification while others resulted from material shortages and some just because the different factories producing the tank got sub-components from different sources. I don't pretend to be an expert on all these differences but do have a general familiarity with the T-34. Both sets I have may be candidates for use on Dragon's T-34 model 1949 and 1940 kits. It's great if you can match the parts combination up with a real example.

Both sets contained 2 complete sets of drive sprockets which are comprised of separate inner and outer wheels. The individual parts come on a surrounding carrier with 'sprue like' connection points. The carrier can be removed without tools just by pressing them away from the connection points. The running surface of the wheels can be easily cleaned up with files or a sanding stick after that. The resin used is hard without being too brittle and allows for extremely fine details to be rendered cleanly. The castle nuts on the type 3 wheels have sharp detail. The wheels mate perfectly once you have found the sweet spot by rotating the parts until they click together.

T-34 Model 1940 Type 1



T-34 Model 1940 Type 3



Both sets contained 2 complete sets of drive sprockets which are comprised of separate inner and outer wheels. The individual parts come on a surrounding carrier with 'sprue like' connection points. The carrier can be removed without tools just by pressing them away from the connection points. The running surface of the wheels can be easily cleaned up with files or a sanding stick after that. The resin used is hard without being too brittle and allows for extremely fine details to be rendered cleanly. The castle nuts on the type 3 wheels have sharp detail. The wheels mate perfectly once you have found the sweet spot by rotating the parts until they click together.

The details look very sharp when compared with those supplied in Dragon's T-34 1939/40 running gear sprue and I can recommend these to anyone building an early T-34. The idea of including 2 sets of sprockets may appeal to someone assembling a collection of T-34's but most of us would be just as happy with single set, especially if that reduced the purchase price. The price from the OKB web site is €10.00 per set which combined with shipping may be a little on the high side for some.

Thanks to OKB-Grigorov for the samples

T-34 Model 1940 sprockets from a Dragon kit for comparison

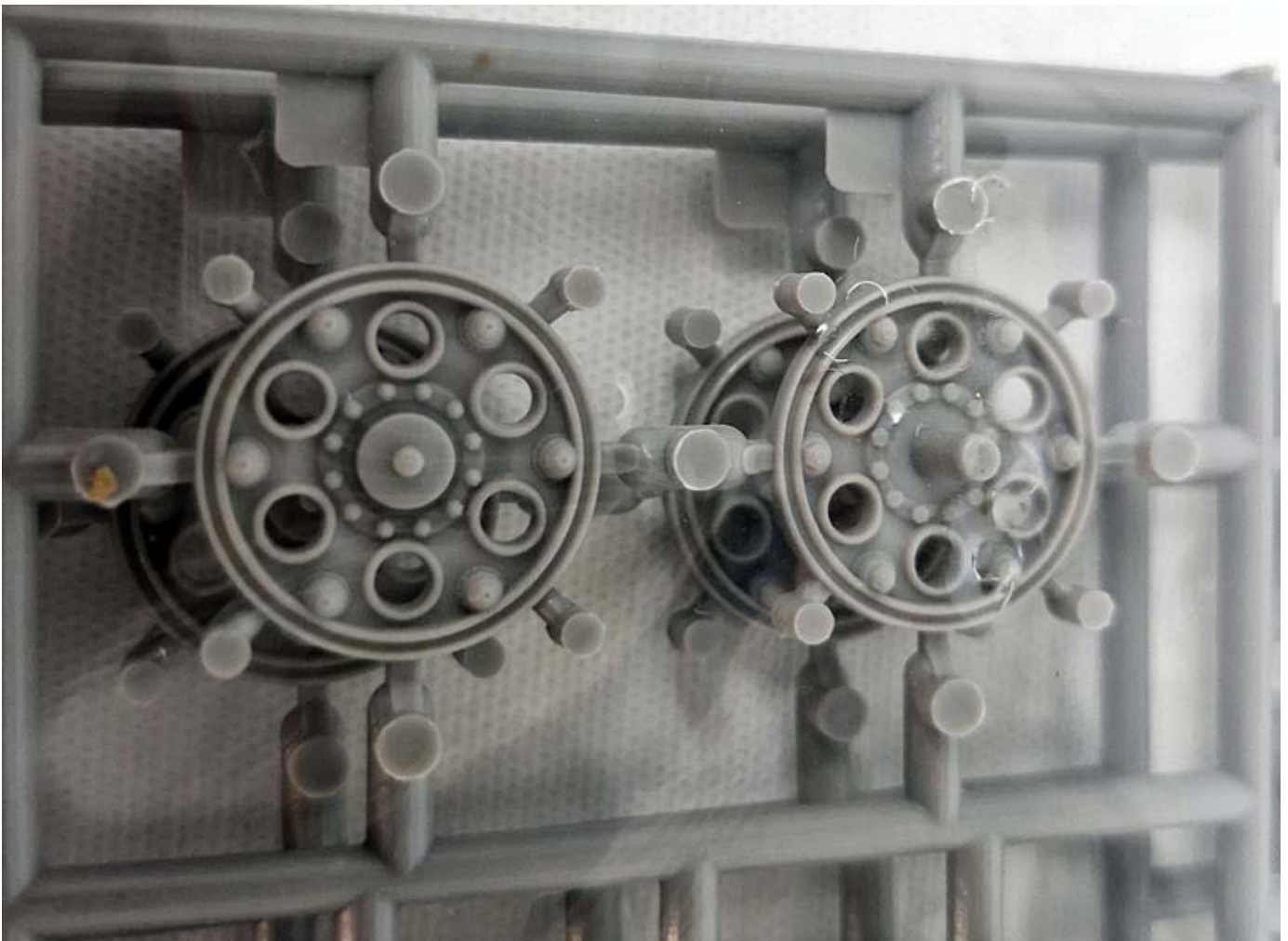

On the table at our December meeting













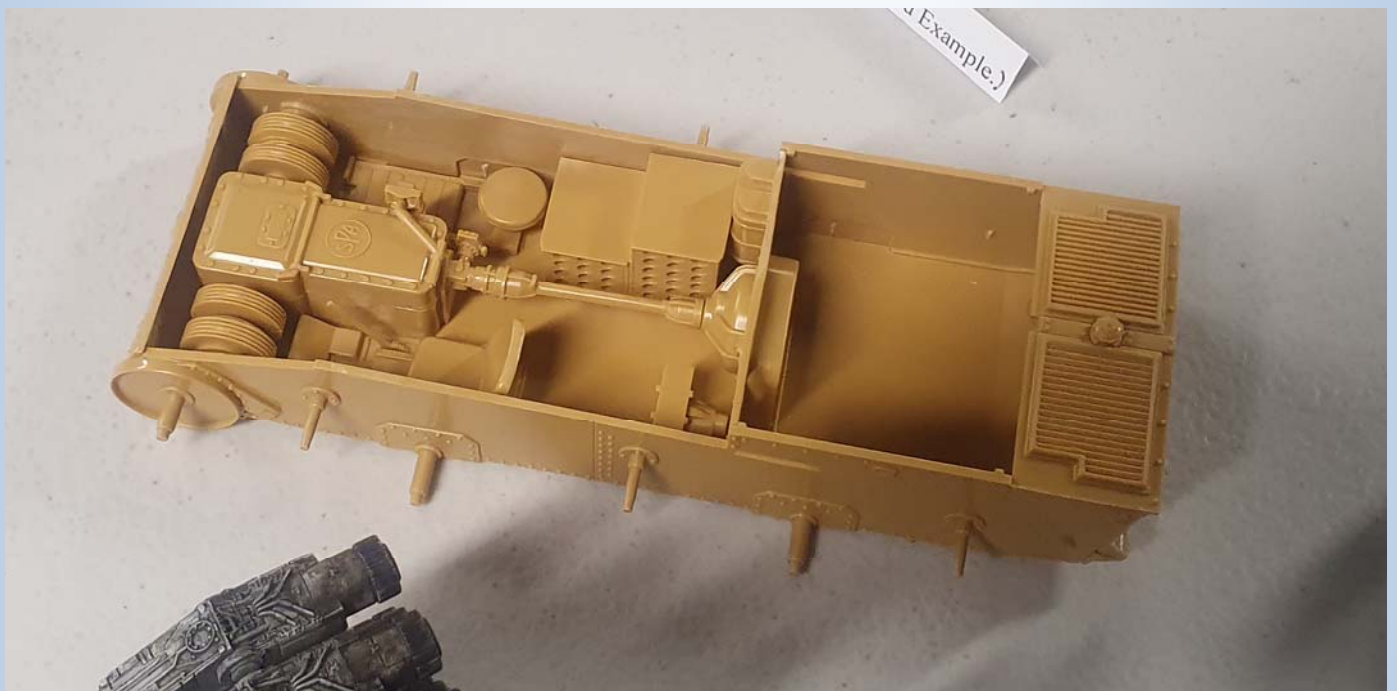























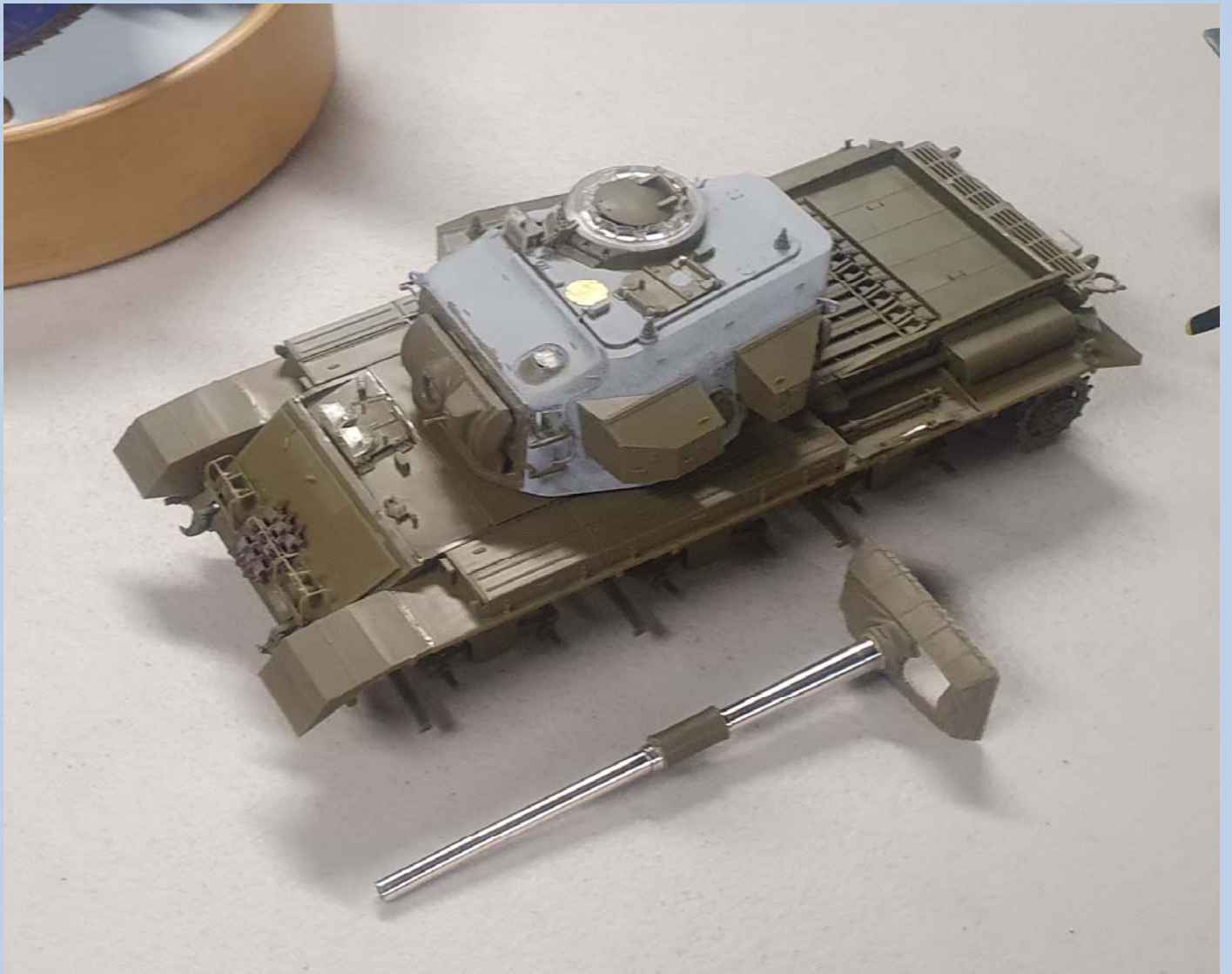





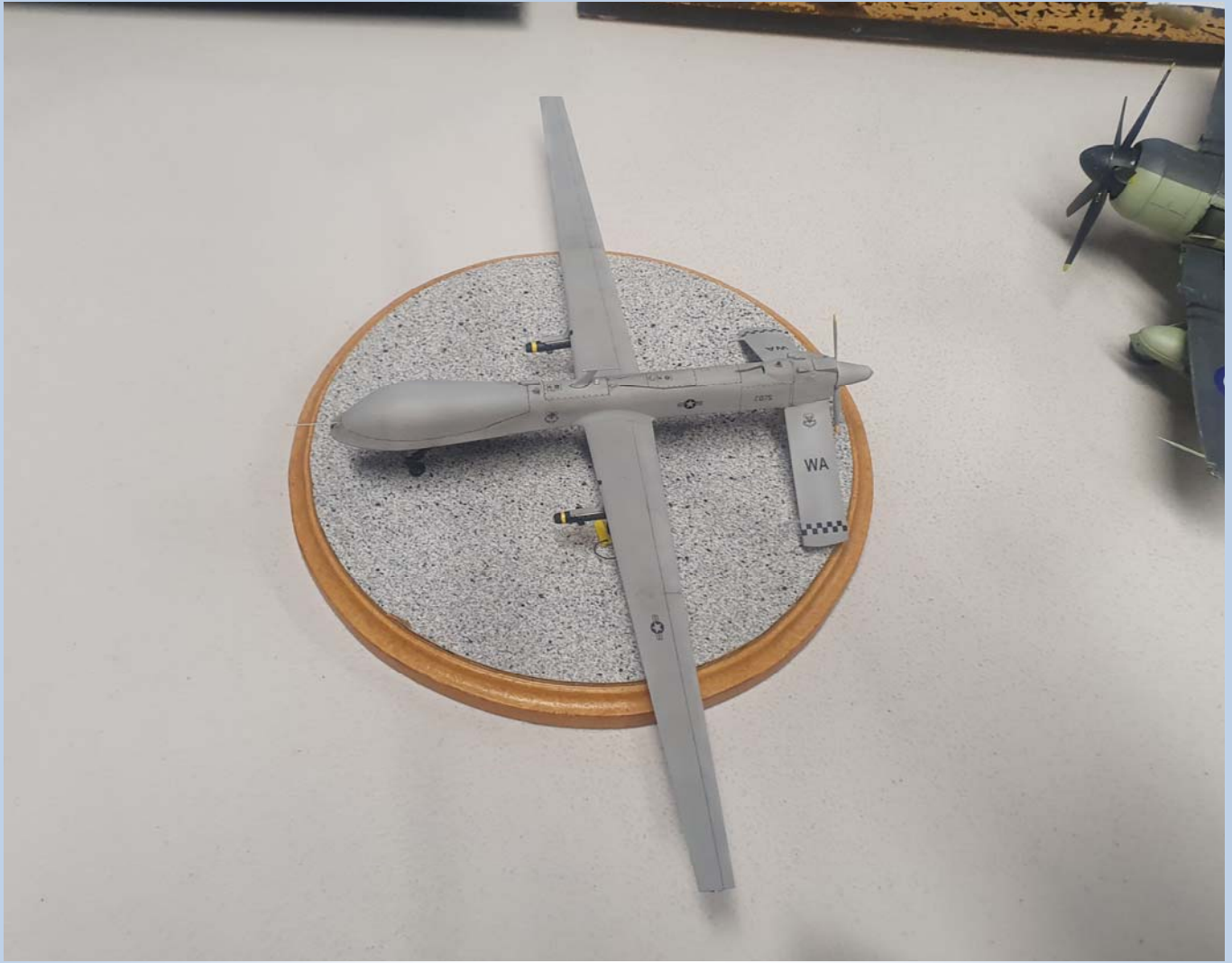



GALLERY

CLUB NIGHT MODELS

Check out our Website gallery for photos taken of models at our monthly meetings

<http://ipmsauckland.hobbyvista.com>



And as usual -check out the IPMS Auckland website as we're trying to keep the content a bit more dynamic. We won't be regurgitating content found on other websites but will provide links to sites we think are of interest to members.

